



**AUTOPILOT**  
SALT CHLORINE GENERATORS

# Pool Pilot<sup>®</sup> *Digital Nano*

## Salt Chlorine Generator

Swimming Pool & Spa Purification System

Models: 75040 and 75041

For use with RC-35/22 Cell, ONLY!



## Owner's Manual

### Installation and Operation

This manual covers the installation and operation of Digital Nano Chlorine Generators equipped with the following Cell & Manifold assemblies (sold separately), Part Numbers: 94105 & 75082.

### **IMPORTANT !**

**Read This Manual Before  
Installing or Operating**

**INSTALLER: THIS DOCUMENT IS PURCHASER'S PROPERTY AND IS TO REMAIN WITH THE EQUIPMENT OWNER**

# OWNER TABLE OF CONTENTS

<b>FACTORY CONTACT INFORMATION .....</b>	<b>3</b>
<b>SAFETY INFORMATION .....</b>	<b>4</b>
<b>OWNER QUICK START &amp; RUN .....</b>	<b>7</b>
How Your Chlorine Generator Works .....	7
Control Overview .....	7
Up and Down Arrows: .....	7
The Boost Button: .....	8
Menu and Select Button:.....	8
Check System Light and Audible Alarm:.....	8
Normal Display: .....	8
Water Balance & Chemistry Recommendations.....	9
Winterizing .....	9
<b>IMPORTANT FEATURES .....</b>	<b>10</b>
Patented Temperature Compensation .....	10
Water Manifolds Assemblies - Two Available Options.....	10
<b>INSTALLER TABLE OF CONTENTS .....</b>	<b>13</b>
<b>REFERENCE SECTION .....</b>	<b>31</b>
Salt Addition Chart: .....	31
Basic Water Chemistry: .....	32
Using the Saturation Index (SI):.....	33
<b>MAINTENANCE .....</b>	<b>34</b>
Fuse Location and Ratings: .....	34
Tri-Sensor Assembly: .....	34
Location of Fuse .....	34
Removing\Inspecting\Cleaning the Tri-Sensor (Pump must be off): .....	35
Testing the Flow Switch, Cleaning the Filter Screen, .....	36
Cleaning the Bypass Valve (for optional 94105 Manifold) .....	36
Servicing the SuperCell .....	37
Removal of the SuperCell... ..	37
Visual Inspection of the SuperCell... ..	37
Inspecting SuperCell (continued): .....	38
Manual Cleaning of the SuperCell... ..	38
Inspecting SuperCell (continued): .....	39
Installing a SuperCell... ..	39
Winterizing .....	39
Spring Start-Up .....	39
<b>TROUBLESHOOTING .....</b>	<b>40</b>

# CONTACT INFORMATION

## What We Need to Know If You need To Contact Us...

If you should need to call AquaCal AutoPilot for questions, service, or parts, please have the following information ready:

INSTALLER - Please record the following information prior to installation:

Installer: _____	Date of Installation: _____
Control Unit Model Type: _____	Control Unit Serial Number: _____
SuperCell Model Type: RC-35/22 (only permitted type) _____	SuperCell Serial Number: _____
	Tri-Sensor Serial Number: _____
Pool Volume in Gallons: _____	
(Pool Volume in Liters:) _____	

## To Contact the Factory...

If you have questions, please refer to our web site at [www.autopilot.com](http://www.autopilot.com) for the latest manual revisions, additional information, and helpful service advice.

You can also call us at: (727) 823-5642. We are here to serve you from 8:00 A.M. to 5:00 P.M. Eastern time, Monday through Friday. If calling after hours, our voice mail system will handle your call. Please be sure to leave your name, a complete address, and your telephone number.

You may also reach us by email at: [AutoPilotTechSupport@teamhorner.com](mailto:AutoPilotTechSupport@teamhorner.com).

Or, if you prefer, you may FAX us at: (727) 824-0847. Be certain to provide your full address and a daytime telephone number.

**Pool Pilot<sup>®</sup>**  
***Digital Nano***

Manufactured by  
AquaCal AutoPilot, Inc.  
2737 24th Street North  
St. Petersburg, Florida 33713  
U.S.A.

# SAFETY INFORMATION

Used and maintained properly, your chlorine generator will provide year-upon-year of safe and economical service. However, as with any mechanical or electrical device, to get the most from your equipment—while insuring personal safety for you and others—certain operational and maintenance factors must be observed.

Likewise, excepting a few minor owner-capable maintenance items (explained later in this manual), repair and service of your chlorinator must be performed only by experienced service personnel. Should you, the owner, suspect your chlorine generator is not performing properly, please refer to the section in this manual entitled: "Troubleshooting," You can also access the most current troubleshooting advice at [www.autopilot.com](http://www.autopilot.com). If you determine that a service call is necessary, your installer can be one source of service, or AquaCal AutoPilot Customer Support can recommend a service company.

Please note that warranties may be voided if the chlorinator has been installed, operated, maintained, or repaired improperly. In addition to voiding the manufacturer's warranty... unapproved installation methods, modifications, poor or incorrect maintenance, service by unqualified personnel, or improper use of the chlorinator may result in personal injury and/or property damage. For personal safety, and to avoid damage to equipment, follow all safety instructions displayed on the equipment and within this manual.

## Safety Signals

Throughout this manual the following two safety signals are placed where particular attention is required. Please note "WARNING" relates to personal safety, while "CAUTION" signals promote avoiding damage to equipment.

<b>WARNING !</b>	Failure to heed the following may result in permanent injury or death.
A "warning" signal appears in this manual where special attention is required for personal safety. <i>(Specific instructions will appear in this box.)</i>	

<b>CAUTION !</b>	Failure to heed the following may result in equipment damage.
A "caution" signal appears in this manual where special care is required to avoid equipment damage. <i>(Specific instructions will appear in this box.)</i>	

Follow all National Electric Codes (NEC) unless State or Local guidelines supersede. When installing and using your NANO, basic safety precautions must always be followed, including the following:

## Safety Information Main Table

<b>WARNING !</b>	Failure to heed the following may result in permanent injury or death.
<b>CHLORINATOR CONTAINS NO OWNER-REPAIRABLE COMPONENTS</b> - Repairs must not be attempted by untrained and/or unqualified individuals. If service is deemed necessary, contact installing dealer or AquaCal AutoPilot Customer Support at: (727) 823-5642.	

<b>WARNING !</b>	Failure to heed the following may result in permanent injury or death.
<b>RISK OF ELECTRICAL SHOCK</b> - A bonding lug has been provided on the outside of the Control Unit. This lug permits the connection of a No. 8 AWG (8.4mm <sup>2</sup> ) solid copper-bonding conductor (No. 6 AWG in Canada). Make this connection between the Control Unit and all other electrical equipment and exposed metal within 5-feet (1.5m) of the Control Unit. All field-installed metal components (such as rails, ladders, drains, etc.) within 10-feet of the pool, spa, or hot tub, must be bonded to the equipment grounding bus using copper conductors not smaller than No. 8-AWG (8.4mm <sup>2</sup> ) (No. 6 AWG in Canada).	

# SAFETY INFORMATION

<b>WARNING !</b>	Failure to heed the following may result in permanent injury or death.
<b>RISK OF ELECTRICAL SHOCK</b> - Disconnect all AC power when installing or servicing this system.	
<b>WARNING !</b>	Failure to heed the following may result in permanent injury or death.
<b>RISK OF ELECTRICAL SHOCK...</b> Insure electrical power is disconnected before wiring the unit. Follow all state / local / NEC (CEC if applicable) electrical codes. Use copper conductors, only.	
<b>WARNING !</b>	Failure to heed the following may result in permanent injury or death.
<b>CHEMICAL HAZARD...</b> To avoid damaging splashes, always add acid to water, never water to acid. Wear safety glasses and use other appropriate personal protection equipment.	
<b>WARNING !</b>	Failure to heed the following may result in permanent injury or death.
<b>WATER CHEMISTRY SAFETY</b> - Improper water chemistry can present a serious health hazard. The proper residual chlorine level and water chemistry must be maintained. The addition of certain pool maintenance chemicals can reduce the effectiveness of chlorine. Maintain Pool / Spa water per standards detailed later in this manual.	
<b>WARNING !</b>	Failure to heed the following may result in permanent injury or death.
<b>CHEMICAL HAZARD...</b> To avoid damaging splashes, always add acid to water, never water to acid. Wear safety glasses and use other appropriate personal protection equipment.	
<b>WARNING !</b>	Failure to heed the following may result in permanent injury or death.
<b>RISK OF ELECTRICAL SHOCK</b> - Control units configured to 115-VAC must be installed at least 10-feet (3 m) from the pool or spa wall. Control units configured to 230-VAC must be installed at least 5-feet (1.5m) from the pool or spa wall.	
<b>WARNING !</b>	Failure to heed the following may result in permanent injury or death.
<b>RISK OF ELECTRICAL SHOCK</b> - A disconnect device, incorporated into the fixed wiring, must be included in the supply circuit (such as a time clock, relay, or circuit breaker).	
<b>WARNING !</b>	Failure to heed the following may result in permanent injury or death.
<b>RISK OF CHILD DROWNING OR INJURY</b> - Children must be closely supervised at all times around pool or spa equipment.	
<b>CAUTION !</b>	Failure to heed the following may result in equipment damage.
The AquaCal AutoPilot Chlorinator must be installed and operated as specified. Failure to do so will void the equipment warranty.	
<b>CAUTION !</b>	Failure to heed the following may result in equipment damage.
To permit proper air circulation, the Control Unit must be mounted at least 1-foot (300 mm) off ground level.	

# SAFETY INFORMATION

## CAUTION !

Failure to heed the following may result in equipment damage.

Special measures are required in the event of freezing conditions. Your Pool Pilot may be damaged if measures are not taken in advance of freezing conditions. Equipment damage due to freezing conditions is NOT covered under the equipment warranty.

## CAUTION !

Failure to heed the following may result in equipment damage.

Do not use a pool cleaner or vacuum head with wheels, as wheels can leave track marks on newly-plastered pools. Do not allow Granular salt to pile up in one location, without brushing, as staining may occur.

## CAUTION !

Failure to heed the following may result in equipment damage.

Excessively high chlorine levels can cause premature cell failure and corrosion damage to pool fixtures and equipment.

## CAUTION !

Failure to heed the following may result in equipment damage.

Always follow the instructions on the manufacturer's label whenever handling or using chemicals.

## CAUTION !

Failure to heed the following may result in equipment damage.

For maximum cell life, maintain water in a balanced condition. Water maintained in a scaling condition will shorten cell life and may render the chlorinator inoperative. Damage and/or service calls, caused by improper water balance, will NOT be covered under the equipment warranty.

## CAUTION !

Failure to heed the following may result in equipment damage.

Scraping or scratching the titanium blade's edge or surface **will** damage the blade catalyst coating and cause premature failure of the cell... warranty will be voided. Never use any sharp or metallic objects to remove scale.

## CAUTION !

Failure to heed the following may result in equipment damage.

The AquaCal AutoPilot chlorinator is equipped with an electronic flow switch that automatically turns the unit off in the event of a "low water flow" situation. Do not tamper in any way with this safety feature.

## CAUTION !

Failure to heed the following may result in equipment damage.

Reduced polarity reversing cycle times will reduce SuperCell life, and should only be used due to uncontrollable scale formation on the Cell. ALWAYS test and adjust water balance, before attempting scale control via shortening reverse period.

## CAUTION !

Failure to heed the following may result in equipment damage.

The Tri-Sensor should not be pulled out at an angle, or the flow paddle or flow post may be damaged.

# OWNER QUICK START & RUN

The Pool Pilot Digital Nano is a salt chlorination system designed for pool or spa water purification. Although the Nano is easy to use, it is important to read through the entire manual before attempting to operate the system.

## A Note Concerning Terminology:

Throughout this manual, the portion of the system which mounts to the wall (and powers the cell) may be referred to as the: *Digital Nano, Pool Pilot, power center, control center, or unit.* In addition, when “pool” is referred to in the absence of the word “spa,” it should be assumed “spa” is inferred (should a spa be present in the installation).

## FCC Compliance:

This device complies with part 15 of the FCC Rules. Operation is subject to the following two conditions: (1) This device may not cause harmful interference, and (2) this device must accept any interference received, including interference that may cause undesired operation.

## How Your Chlorine Generator Works

The system requires a low concentration of dissolved salt (sodium chloride) in the water. The salt concentration level is normally maintained below the taste threshold. The Nano automatically converts the salt into chlorine, which your pool/spa requires to remain sanitized and algae free. The chlorine reverts back to salt after treating the water. Since the salt is constantly recycled, there is minimal loss during a swimming season. However, salt can be lost due to filter backwashing, rain water overflow, leaks, or bather splashing/carry out... but not through evaporation.

The Digital Nano is designed to handle the purification needs of residential swimming pools and spas. The amount of chlorine required for proper sanitization will vary based on the pool size and various factors such as water temperature, bather load, exposure to direct sunlight, and special water features.

The water circulation pump must be operating for your Nano to produce chlorine, so run time is one of several key components to maintaining the proper sanitizer levels. **Most installations require a minimum of eight (8) hours-per-day pump run time** to properly filter and sanitize the water.



## Control Overview

Following is a brief explanation of owner / operator control options. For full features of the Owner Options Menu, please see page-26. The MENU button is pressed to obtain access to the Owner Options Menu.

**Please Note:** This section assumes the installer has already programmed the system for specific site parameters, has established proper water balance, and has pretreated water to 1 - 3 ppm chlorine.

**Attention Owner:** should centigrade vs. fahrenheit, choice of language, or other owner options require modification, please refer to the programming information located on page-26. See: *Menu Button* and *Owner Options.*

### **Up and Down Arrows:**

Use the UP and DOWN arrows to control the **purifier output level**, then press the SELECT button to save the value chosen. With a properly prepared pool, the recommended starting output level is 50%.

Upon initial start-up, check sanitizer level every few days and make small output level adjustments as necessary to maintain 1-3 ppm free chlorine levels. Keep in mind, your Nano does *not* directly measure or regulate the sanitizer levels in your pool. Rather, the owner / operator will need to periodically test the water to determine the current chlorine level, and adjust the **output setting** as needed.

After the purifier output level is “tuned in,” the unit will automatically make fine output adjustments as the water temperature fluctuates. This temperature compensation feature will adjust output depending on water temperature. See page-11 for more information concerning the temperature compensation feature.

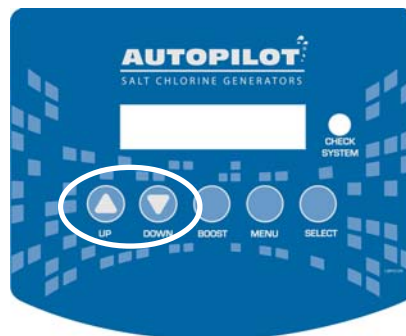

# OWNER QUICK START & RUN

**Please Note:** The **optimum output setting** will vary based upon pool size, location, exposure to sunlight, number of users, vegetation around the pool, water balance practices, and pump run time. Your installer should have already taken these factors into consideration when performing installation programming. Therefore, your adjustments, at this point, should be relatively minor.

## ***The Boost Button:***

The BOOST button increases output to 100%. Use this feature when a heavier than normal bather load is anticipated.

Press BOOST once..... = 24-Hour Boost

Press and hold BOOST for 8 seconds= 72-Hour Boost

Press BOOST a second time..... = Deactivate Boost

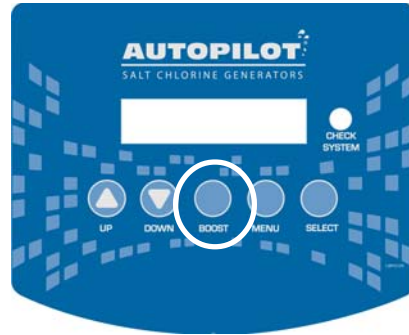

## ***Menu and Select Button:***

Allows access to the “Test,” “Setup,” “Owner Option,” “Maintenance,” and “Installer” menus. The SELECT button allows the operator to choose program menu options. The owner / operator should not normally need to access these features on a regular basis. Consult “Programming” section, or contact factory customer support for additional information.

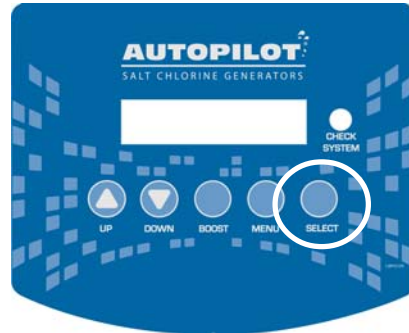

## ***Check System Light and Audible Alarm:***

The CHECK SYSTEM light will flash to warn the unit *may* need attention. A warning message will also be displayed. If enabled, an audible alarm\* may also be heard when the system light is flashing. Unless deemed a normal condition, per below, see troubleshooting section beginning on page-41.

- Flashes red when pump is off / water flow is insufficient. (Normal if the water pump is off)
- Flashes when salt is low
- Flashes when water temperature exceeds 125°F, or drops below 10°F

\* **NOTE:** WHEN ENABLED, AN AUDIBLE ALARM WILL SOUND DUE TO ANY OF THE ABOVE THREE (3) CONDITIONS. IF WATER FLOW CEASES (OR FALLS BELOW MINIMUM ACCEPTABLE LEVELS), THE ALARM WILL AUTOMATICALLY SILENCE AFTER 10-MINUTES. TO ENABLE OR DISABLE AUDIBLE ALARM, SEE “AUDIBLE ALARM” PROGRAMMING INSTRUCTIONS LOCATED ON PAGE-29.



## **Normal Display:**

Purifier Output level .....: In 1% increments, from 0% to 100%

Water Temperature .....: In Fahrenheit or Celsius

Cell Status .....: ON or OFF

Check System Light .....: OFF when operating normally

Check System Light .....: Normally blinking when water pump is off and supply power to the controller remains on.



# OWNER QUICK START & RUN

## Water Balance & Chemistry Recommendations

Proper water balance is critical to the operation of your Nano Sanitizer.

Conditions such as high pH levels, low cyanuric acid (stabilizer ) levels, or other factors causing *unbalanced water*, will mask the sanitizer production of your Nano. Please note the following recommended water chemistry parameters:

PH.....	: 7.2 – 7.8
Calcium Hardness.....	: 200 – 400 ppm
Total Alkalinity.....	: 80 – 100 ppm
Salt.....	: 2500 – 3500 ppm (ideal 3000 ppm)
Cyanuric Acid (stabilizer ).....	: 60 – 80 ppm
Chlorine.....	: 1 – 3 ppm

See “Basic Water Chemistry,” on page-33, and “Using the Saturation Index, on page-34, for further information concerning pool/spa water chemistry maintenance requirements.

Should you have additional water balance or chemistry questions, please refer the *Troubleshooting* section in the back of this manual. For additional assistance, please contact factory Customer Support per the information provided on page-4 of this manual.

## Winterizing

### **CAUTION !**

Failure to heed the following may result in equipment damage.

Special measures are required in the event of freezing conditions. Your Pool Pilot may be damaged if measures are not taken in advance of freezing conditions. Equipment damage due to freezing conditions is NOT covered under the equipment warranty.

# Important !!!

## Information Critical to the Survival of Your Pool Pilot Follows...

### Freeze Protection & Extended Shut Down:

In areas where freezing conditions are a rare occurrence, allow the filtration system to run continuously throughout the freeze period. Typically, during light freeze conditions, circulating (moving) water will not freeze.

In areas where freezing conditions are prevalent and sustained, the Pool Pilot MUST be winterized; please refer to winterizing instructions on page-40.

## IMPORTANT FEATURES

- Patented temperature compensation for chlorine output control...
- Programmable microprocessor control...
- Multi-language digital display (English, Spanish, & French)...
- Digitally controlled power to the SuperCell...
- Tri-sensor circuitry to monitor water flow, water temperature, and salt level. Calculates and provides recommended salt addition amounts required to maintain the recommended 3000 ppm (3.0 g/l) salt concentration level.

### **Patented Temperature Compensation**

The Tri-Sensor temperature sensor works in conjunction with the purifier % feature to automatically adjust chlorine output based upon changes in water temperature. The automatic compensation feature operates between 55°F and 125°F (13°C - 52°C).

As water temperature falls below 65°F (18°C), the controller will activate a high purifier percent lockout, and may not allow purifier adjustments up to 100%. This feature prevents the controller from over-driving the cell under colder temperatures, thus preventing premature cell wear.

At 55°F (13°C) or colder water temperatures, the controller will adjust to a fixed 1% output, thus preventing over-chlorination and premature cell failure.

As the water temperature rises above set point, the controller will adjust at 5% per °F up to 100%, thus preventing under-chlorination during warmer water temperatures.

### **Water Manifolds Assemblies - Two Available Options**

The Nano Digital may be operated with either the Inline-Cell Manifold Assembly (#75082), or the Patented Automatic-Flow Bypass Manifold Assembly (#94105). Use with RC-35/22 cell, ONLY!

Please see Installer section: "Basic System Overview," for details and diagrams on both assemblies.

# **Pool Pilot<sup>®</sup>**

# *Digital Nano*

## **Salt Chlorine Generator**

Swimming Pool & Spa Purification System

Models: 75040 and 75041

For use with RC-35/22 Cell, ONLY!

## **INSTALLER-SPECIFIC INFORMATION FOLLOWS**

This manual covers the installation and operation of Digital Nano Chlorine Generators equipped with the following Cell & Manifold assemblies (sold separately): Part Numbers 94105 & 75082.

**INSTALLER: THIS DOCUMENT IS PURCHASER'S PROPERTY AND IS TO REMAIN WITH THE EQUIPMENT OWNER**

# INSTALLER TABLE OF CONTENTS

<b>FACTORY CONTACT INFORMATION .....</b>	<b>3</b>
<b>SAFETY INFORMATION .....</b>	<b>4</b>
<b>SPECIFICATIONS .....</b>	<b>14</b>
Input Power: .....	14
Chlorine Output: .....	14
Manifold Flow Requirements: .....	14
Agency Approvals: .....	14
<b>INSTALLATION.....</b>	<b>15</b>
Before Installing: .....	15
What is included: .....	15
What is NOT included with Control Center: .....	15
Two Available Water Manifolds Assemblies: .....	16
Automatic-Flow Bypass Manifold Assembly (#94105) .....	16
Inline-Cell Manifold Assembly (#75082) .....	17
Basic System Overview: .....	17
Shown with Automatic-Flow Bypass Manifold Assembly (#94105): .....	17
Shown with Inline-Cell Manifold Assembly (#75082) .....	17
Installation Steps: .....	18
Plumbing Requirements: .....	18
Plumbing the Manifold Assembly: .....	18
Flow Rates Within Normal Range: .....	18
Flow Rates Exceeding 100-gpm (379 L/m) .....	19
Mounting the Control Unit: .....	19
Electrical Requirements: .....	19
Electrical Connections: .....	20
High (Line) Voltage Wiring for Model 75081: .....	20
Grounding and Bonding: .....	20
Connecting 75041 Digital Nano to an External Timer or Controller .....	21
Connecting the Tri-Sensor Cable (reference diagram, below)... ..	21
Low Voltage Wiring: .....	21
Connecting the SuperCell Cable (reference diagram, below)... ..	21
Low-Voltage Cable Connections at Control Center .....	21
<b>PREPARING THE POOL WATER .....</b>	<b>22</b>
Installer Please Note: .....	22
Steps to Prepare Water: .....	22
Calculating Pool Volume: .....	22
<b>PREPARING THE POOL WATER .....</b>	<b>23</b>
Adding Salt: .....	23
Type of Salt to Add... ..	23
Determine Amount of Salt Required (and salt level to maintain)... ..	23
Add Salt to Pool Water... ..	23
How to add the salt (or remove it if too much)... ..	23
Operation of Buttons: .....	24

# INSTALLER TABLE OF CONTENTS

<b>MENU OVERVIEW .....</b>	<b>24</b>
<b>ACCESS TO PROGRAMMING .....</b>	<b>24</b>
<b>PROGRAMMING .....</b>	<b>25</b>
Menu Button.....	25
Select Button.....	25
View setup.....	25
Programming at Installation: .....	26
Review of Installer, Owner, & Maintenance Menu Programming: .....	26
Pool Volume: .....	26
Calibrating Salt: .....	26
Select Language: .....	26
Calibrating Temperature: .....	27
Select Units: .....	27
Temperature: .....	27
Set Reverse Time: .....	27
Basic Operational Programming: .....	28
Adjusting the Purifier Output % ... ..	28
Boost or SuperBoost.....	28
Basic Operational Programming (continued): .....	29
Boost or SuperBoost (continued) ... ..	29
Control Options: .....	29
Purifier Mode .....	29
Purifier % Adjustment Procedure: .....	29
.....	29
<b>REFERENCE SECTION .....</b>	<b>31</b>
Salt Addition Chart: .....	31
Basic Water Chemistry: .....	32
Using the Saturation Index (SI):.....	33
<b>MAINTENANCE .....</b>	<b>34</b>
Fuse Location and Ratings: .....	34
Tri-Sensor Assembly: .....	34
Location of Fuse .....	34
Removing\Inspecting\Cleaning the Tri-Sensor (Pump must be off): .....	35
Testing the Flow Switch, Cleaning the Filter Screen, .....	36
Cleaning the Bypass Valve (for optional 94105 Manifold) .....	36
Servicing the SuperCell .....	37
Removal of the SuperCell... ..	37
Visual Inspection of the SuperCell... ..	37
Inspecting SuperCell (continued): .....	38
Manual Cleaning of the SuperCell... ..	38
Inspecting SuperCell (continued): .....	39
Installing a SuperCell... ..	39
Winterizing .....	39
Spring Start-Up .....	39
<b>TROUBLESHOOTING .....</b>	<b>40</b>

# SPECIFICATIONS

## Input Power:

Model 75040.....: 110-120 VAC, 2.0 Amp

Model 75041.....: 220-240 VAC, 1.0 Amp

## Chlorine Output:

SuperCell Type RC-35/22 (ONLY): Maximum Chlorine Output of RC-35/22 cell is 0.8 lbs /day (0.36 kg / day)

## Manifold Flow Requirements:

Minimum Flow Rate.....: 20-gallons per minute (gpm) (76 liters/minute (L/m))

Maximum Flow Rate.....: 100-gallons per minute (gpm) (379 liters/minute (L/m))

Maximum Op. Pressure.....: 85-psi

## Agency Approvals:

Tested to conform to the following specifications:

UL1081.....: Standard for Safety for Swimming Pool Pumps, Filters, and Chlorinators

CAN/CSA-E60335-1.....: Safety of Household and Similar Electrical Appliances

### **Installer... please record the following information on page-6 of this manual:**

- Date of Installation
- Control Unit Model (Type should be # 75040 or # 75041)
- Control Unit Serial Number
- RC-35/22 SuperCell Serial Number
- Tri-Sensor Serial Number

### **For questions concerning installation or operation of this equipment:**

Visit [www.autopilot.com](http://www.autopilot.com) for latest manual revisions and helpful troubleshooting tips.

**-or-**

Run the "View Setup" (page-27) and record the information displayed; have the following information available prior to contacting AquaCal AutoPilot Customer Support:

- Current Measured Salt Level
- Software (SW) Versions

Contact factory Customer Support by dialing: (727) 823-5642... or by email at [AutoPilotTechSupport@teamhorner.com](mailto:AutoPilotTechSupport@teamhorner.com) ... or by FAX at: (727) 824-0847.

# INSTALLATION

## A Note Concerning Terminology:

Throughout this manual, the portion of the system which mounts to the wall (and powers the cell) may be referred as the: *Digital Nano, Pool Pilot, power center, control center, or unit*. In addition, when “pool” is referred to in the absence of the word “spa,” it should be assumed “spa” is inferred (should a spa be present in the installation).

## Before Installing:

- Determine everything needed for installation is on hand.
- Determine where the Manifold Assembly will be plumbed.
- Identify a suitable mounting location for the Control Unit within proper cord length to the manifold.
- Plan runs for SuperCell and Tri-Sensor Cables.
- Plan wire runs and wiring connections for source power.
- Determine origination point for control center power feed:
  - Directly from a circuit breaker... Circuit breaker is used to power the Digital Nano and circulation pump.
  - From an external timer, or
  - From an electronic controller } Digital Nano is to be wired to the same location as the circulation pump; the Digital Nano is activated when the circulation pump is energized.
- Determine whether the input voltage for the Digital Nano will be 115-VAC (as with Model 75040), or 230-VAC (as with Model 75041).

## What is included:

Although the manifold assembly may be sold separately, both a manifold and a Digital Nano Control Center are required for a complete installation. The standard cell & manifold assembly is available with the RC-35/22 residential cell. Before attempting the installation, verify the following items have been included with the Control Center:

### 75040 DIGITAL NANO CONTROLLER

Quantity	Item Description
1	Power Cord with 110 VOLT plug
1	SuperCell Cable
4	Plastic Anchors
4	Mounting Screws

### 75041 DIGITAL NANO CONTROLLER

Quantity	Item Description
2	6' Power Leads
1	SuperCell Cable
4	Plastic Anchors
4	Mounting Screws



Screws and Anchors

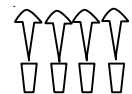

SuperCell Cable

## What is NOT included with Control Center:

- Power service electrical wire.
- ½" liquid tight (nonmetallic flex) conduit.

*Manifold Options Follow on Next Page...*

# INSTALLATION

## Two Available Water Manifolds Assemblies:

### *Inline-Cell Manifold Assembly (#75082)*

The manifold is connected into the plumbing after all other equipment. Water from the pool/spa is moved through the manifold by the circulation pump. The manifold's key components are the Tri-Sensor and SuperCell.

The Tri-Sensor provides data (from electronic sensors) to the Control Unit for monitoring water flow, water temperature, and salt concentration level. The Control Unit uses this data to determine if conditions are safe for the SuperCell to operate; the signal read from the temperature sensor allows the automatic temperature compensation feature to function.

The RC-35/22 SuperCell receives power from the Control Unit and converts the salt contained in the water to chlorine.

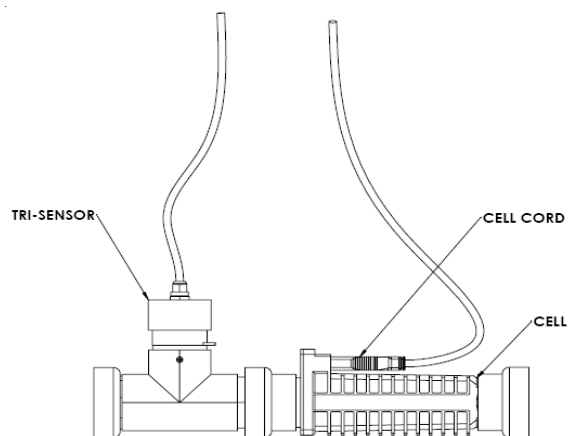

SEE INSTALLATION DIAGRAM, NEXT PAGE

### *Automatic-Flow Bypass Manifold Assembly (#94105)*

The manifold is connected into the plumbing after all other equipment. Water from the pool/spa is moved through the manifold by the circulation pump. The manifold's four key components are the: Strainer Screen, Tri-Sensor, SuperCell, and Bypass Flow Valve.

The Strainer Screen prevents debris in the water from entering the Tri-Sensor or SuperCell, and requires periodic inspection and cleaning.

The Tri-Sensor provides data (from electronic sensors) to the Control Unit for monitoring water flow, water temperature, and salt concentration level. The Control Unit uses this data to determine if conditions are safe for the SuperCell to operate; the signal read from the temperature sensor allows the automatic temperature compensation feature to function.

The RC-35/22 SuperCell receives power from the Control Unit and converts the salt contained in the water to chlorine.

The Bypass Valve allows the water flow rate to be slowed and optimized through the SuperCell, while permitting the pump to continue to circulate water to-and-from the pool/spa at full flow rates. The slowed water flow through the SuperCell results in a more efficient "Super-Chlorination" effect, resulting in improved overall sanitization.

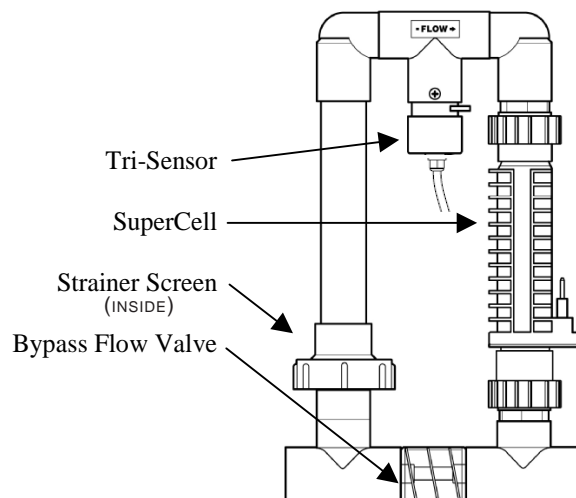

SEE INSTALLATION DIAGRAM, NEXT PAGE



# INSTALLATION

## Basic System Overview:

The Nano Digital unit is a salt chlorination system for pool or spa purification, and is designed to operate in the following configurations:

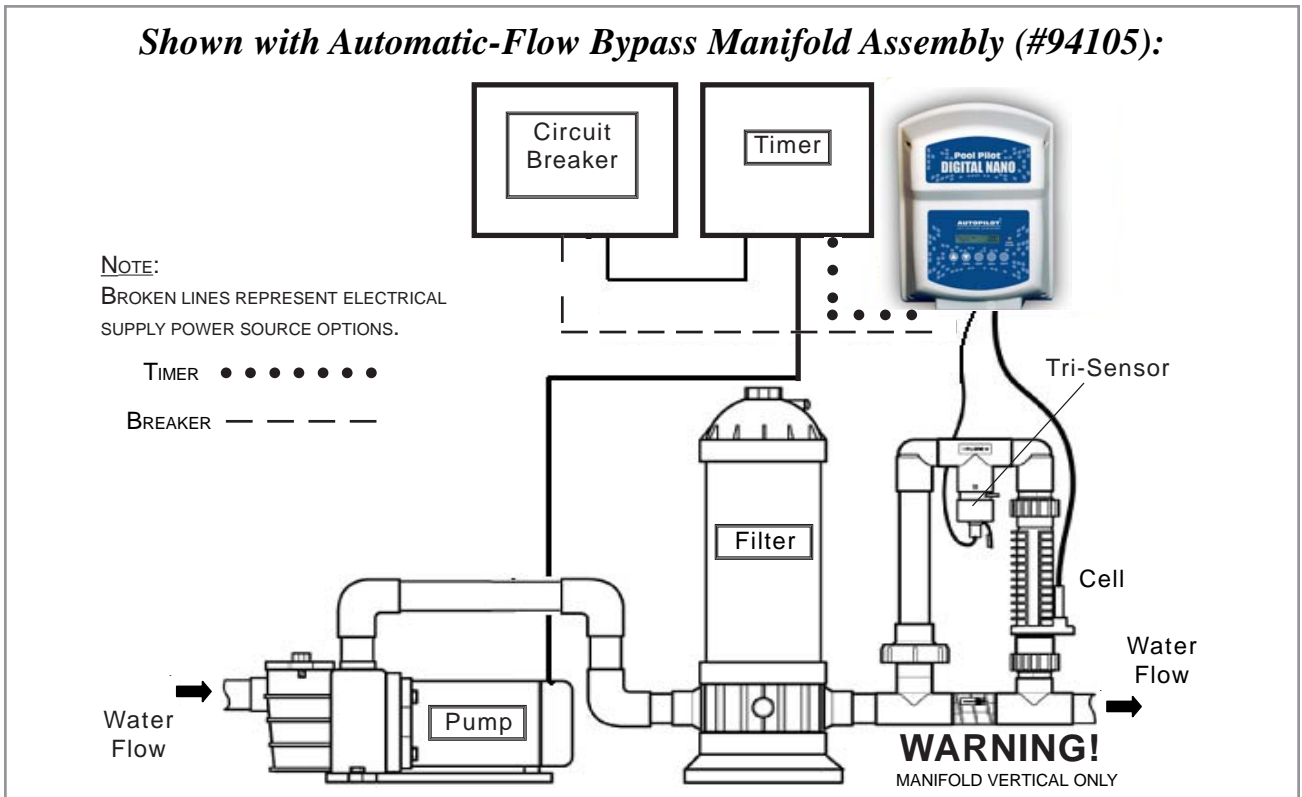
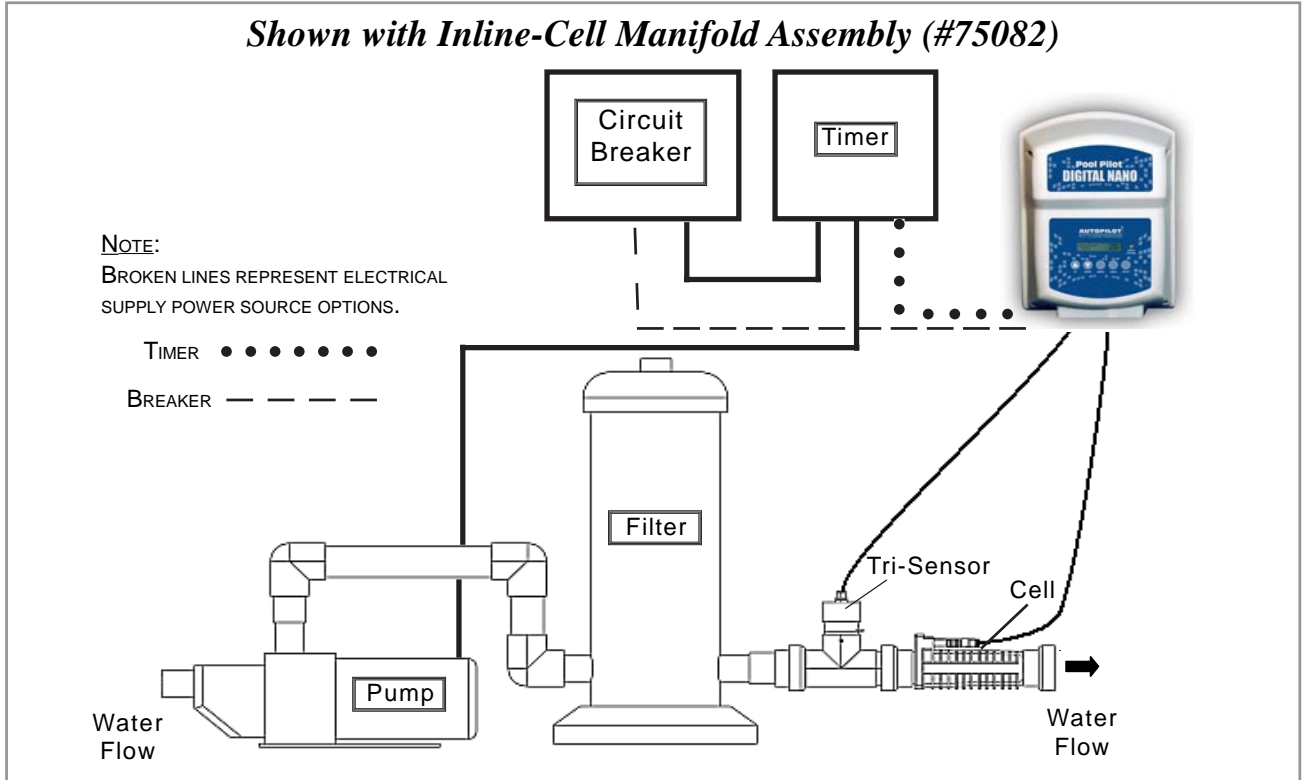

# INSTALLATION

## Installation Steps:

Details on each step of the installation process are presented on the following pages:

1. Plumbing the Manifold Assembly (see below)
2. Mounting the Control Unit (page-20)
3. Electrical Requirements & Connections (pages 20-21-22)
  - a. Grounding and bonding
  - b. Line (high) voltage wiring (Pool Pilot Digital Nano to an external timer or controller)
  - c. Low voltage wiring
    - SuperCell cable
    - Tri-sensor cable
4. Preparing the Water (pages-23 & 24)
5. Programming and Setup for Site Parameters. (pages 25-31)

## Plumbing Requirements:

The Manifold Assembly is 2" Schedule 40 PVC, and is typically plumbed into the pool return line; and, if applicable, after the heater and spa return diverter valve.

## Plumbing the Manifold Assembly:

**STEP-1:** Select the location for installing the manifold:

- It is recommended the manifold be installed prior to installation of the Control Unit. The Control Unit must be installed close enough to the Manifold Assembly to allow the Tri-Sensor and SuperCell cables sufficient slack to enable component service and maintenance. The cables are 12' long.
- If using the Bypass Manifold/Cell (# 94105), the assembly must be installed in a vertical orientation as illustrated in the diagram on previous page. This orientation prevents hazardous gas buildup in the system, should the flow switch fail to detect insufficient flow. **WARNING! Place manifold vertical ONLY.**
- The direction of the water flow through the manifold must be as indicated for the system to operate properly.
- For a Pool/Spa combination, the manifold must be located as the last component in the POOL RETURN LINE (to avoid over-sanitization of the spa).

## Flow Rates Within Normal Range:

- The manifold can be directly plumbed into the system (as shown in the diagrams on the prior page).
- If the flow rate for the system is less than 20-gpm (76 L/m), a larger pump must be installed (or steps taken to improve flow rate).

*Note: Insure flow rates for two-speed pump can provide sufficient flow at low speed.*

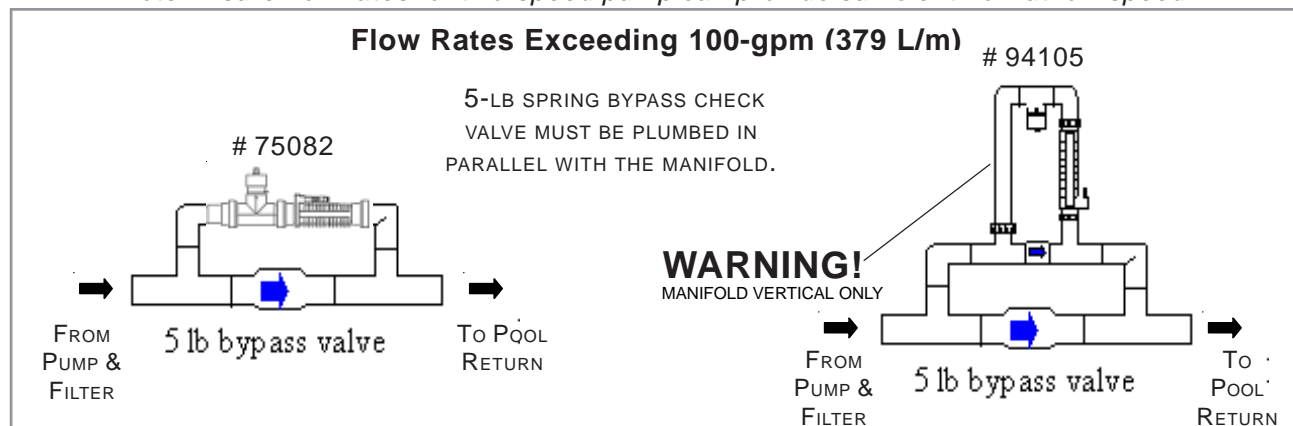

# INSTALLATION

Plumbing the Manifold Assembly (continued):

**STEP-2:** The manifold will accept an RC-35/22 residential cell; use of any other cell may damage the power supply and the equipment warranty will be voided. **CAUTION! Use RC-35/22 cell ONLY.** Install the cell into the manifold. Tighten the unions by hand for a watertight seal.

## Mounting the Control Unit:

*All electrical connections should be made by a licensed electrician or certified electrical contractor.*

The Digital Nano power center is suitable for indoor or outdoor mounting. When connected to 230-VAC, the power center must be installed at least 5' (1.5 m) horizontal distance from the pool or spa wall. When connected to 115-VAC, the power center must be installed at least 10' (3 m) horizontal distance from the pool or spa wall. Greater distances may be required by local codes.

The Digital Nano power center is designed to mount vertically on a flat surface with the wiring inputs facing downward. The enclosure is designed to allow heat to dissipate from inside the box. It is important to not block the top or bottom of the enclosure.

Do **NOT** mount the power center inside a panel or a tightly enclosed area lacking proper and full ventilation.

When selecting a location for installing the power center, please note the Tri-Sensor and SuperCell cables are 12' (3.6 m) long.

**ATTENTION:** verify the selected power center location is close enough to the Manifold Assembly to allow the Tri-Sensor and SuperCell Cables sufficient slack to accommodate later service and maintenance.

**To avoid damage to wiring and connectors, thoroughly read the following section before proceeding:**

1. Hold the power center chassis in the selected mounting location. Through the top, narrow portion of mounting slots, mark the wall for the four (4) mounting holes.
2. Plastic anchors and screws have been provided for concrete or stucco walls; anchors are not required when mounting to wood or composite materials. Drill and install the plastic anchors (as applicable). Using a screwdriver, run the screws into the anchors, leaving a ¼" gap between the wall and the underside of the screw heads.
3. Holding the power center slotted openings to the screw heads, allow the screw heads to pass through the larger portion of the mount holes; hang the power center on the four (4) mounting screws; using a long shaft screwdriver, tighten the screws.



## Electrical Requirements:

The 75040 Digital Nano has been configured for 115-VAC operation. The Digital Nano 75041 has been factory configured for 230-VAC operation. The configuration can be changed in the field.

The reconfiguration from 110 to 230-VAC requires removal of the power cord, and changing jumpers inside the unit. Also, the fuse has to be changed: 1-amp slow blow for 230-VAC (110-VAC units use a 2-amp slow blow fuse). See further instructions located under the power center cover.

## **WARNING !**

Failure to heed the following may result in permanent injury or death.

**RISK OF ELECTRICAL SHOCK...** Insure electrical power is disconnected before wiring the unit. Follow all state / local / NEC (CEC if applicable) electrical codes. Use copper conductors, only.

# INSTALLATION

## Electrical Connections:

The control center uses both high (line) and low voltage connections. Line-voltage connections are intended as electrical input to the power center. Low-voltage cables connect to the Tri-Sensor and SuperCell.

### **WARNING !**

Failure to heed the following may result in permanent injury or death.

**RISK OF ELECTRICAL SHOCK...** Insure electrical power is disconnected before wiring the unit. Follow all state / local / NEC (CEC if applicable) electrical codes. Use copper conductors, only.

## Grounding and Bonding:

- Connect the green ground wire to the supply ground.
- The Digital Nano must also be connected to the pool/spa bonding system with an 8-AWG (6-AWG for Canada) wire. A bonding lug is provided at the bottom, exterior of the control center.

## High (Line) Voltage Wiring for Model 75081:

The Digital Nano LTP0058 # 75041 is typically provided input power in one of two ways. Determine which is best for your application. (Note: the **75040** comes supplied with an attached, 110-VAC cable, and can be connected into a time clock or 110-VAC outlet.)

- **AC input directly from a circuit breaker, time clock, or pump relay external controller:** This method is used when the AC power to the pump and Pool Pilot will be turned on and off by an external device such as a circuit breaker, time clock, or electronic controller.
- **AC input directly from an ORP controller:** Chlorine production will be controlled by external ORP controller.

### *Connecting 75041 Digital Nano to an External Timer or Controller*

1. Measure and cut ½" nonmetallic flexible conduit to reach from the power source to the Nano Digital.
2. Feed the wires from Nano through the conduit.
3. At time clock or external controller relay, connect AC power wiring to the LOAD SIDE or the same location as the circulation pump wires (pump connected to circuit breaker, time clock or electronic controller).
4. Connect the ground wire to the ground of the power source.

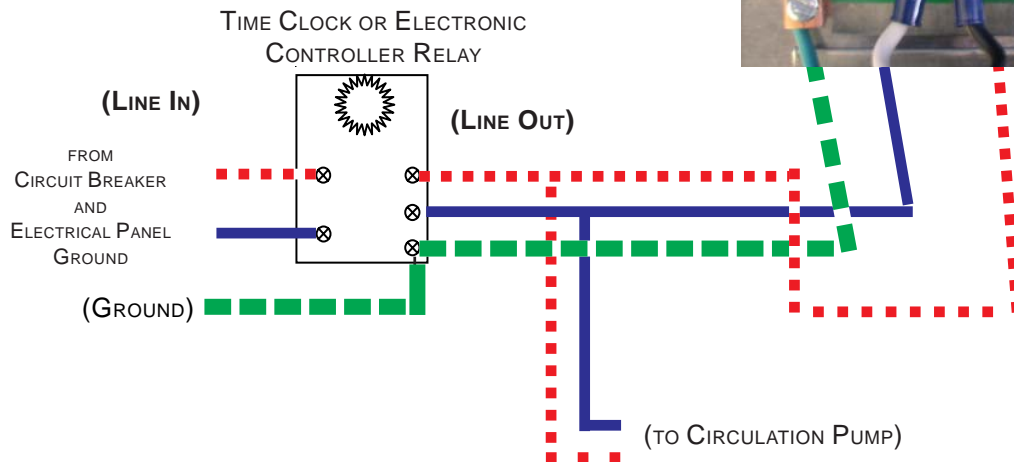
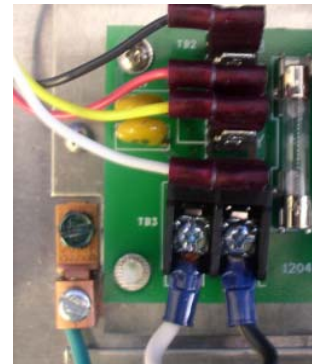

# INSTALLATION

## Low Voltage Wiring:

### *Connecting the SuperCell Cable (reference diagram, below)...*

1. The SuperCell cable connector is keyed and must be aligned to connect properly. Line up the cell cord and plug into the cell cord connector located on the bottom right of the Digital Nano base plate.
2. The other end of the SuperCell cable will have a red weather plug located in one of the three (3) contact holes. The SuperCell will have two (2) electrical terminals:
  - As the SuperCell has two (2) electrical contact terminals, the red weather plug will seal the unused contact in the cable.
  - Position the SuperCell plug to align the two open holes with the two mating cell terminals: push gently, but firmly, to connect.

### *Connecting the Tri-Sensor Cable (reference diagram, below)...*

The Tri-Sensor Cable is 12-ft long (3.4m) and connects the Tri-Sensor Assembly to the Control Center. Connect the white 6-pin connector to the mating plug located on the base of the Digital Nano.

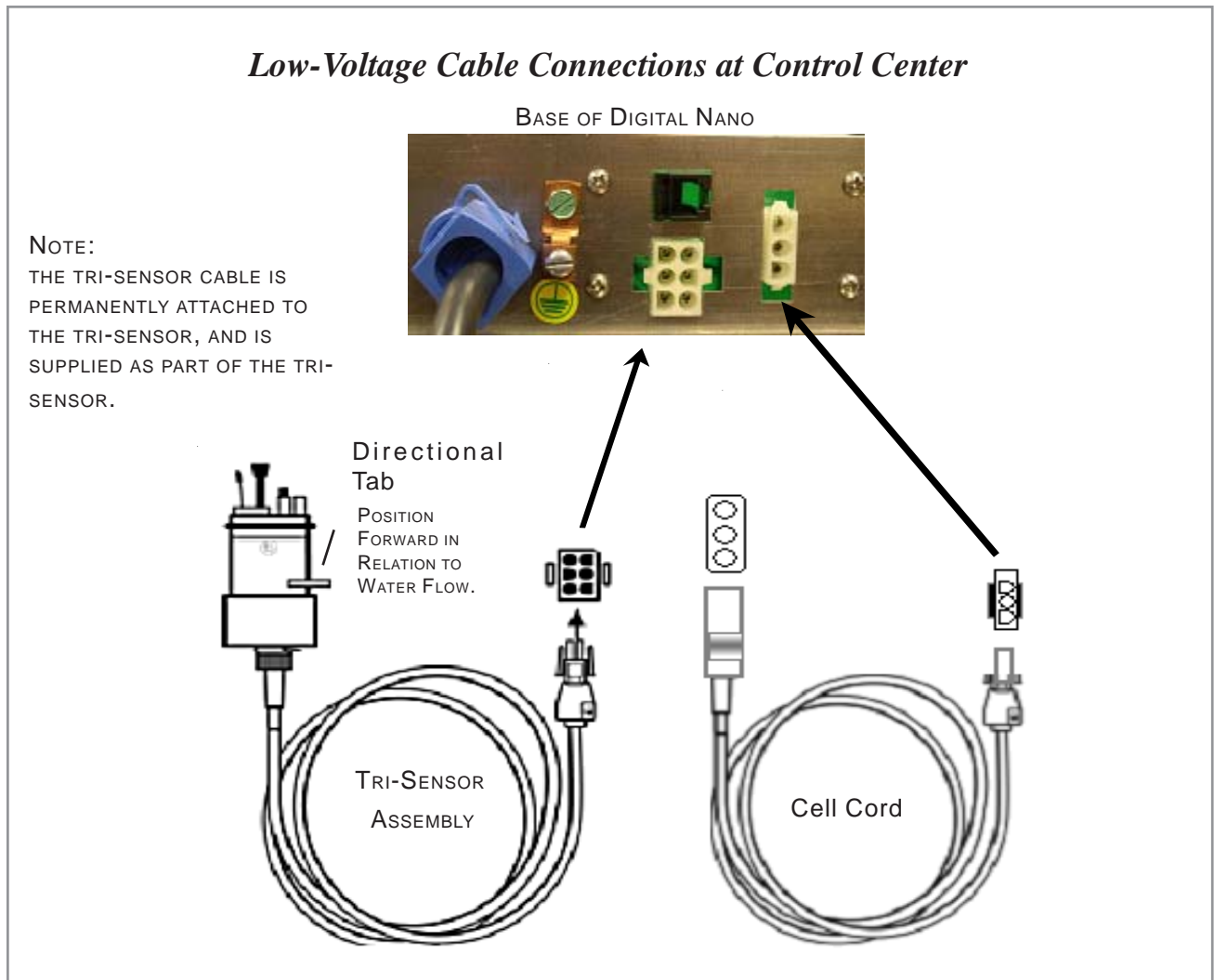

# PREPARING THE POOL WATER

## Installer Please Note:

When properly sized to the site, the Digital Nano will meet the sanitizer “maintenance” requirements of the pool/spa. The Nano is *not* designed to chlorine shock treat, or build up a chlorine residual, when starting with a zero or very low chlorine level.

Before starting the Nano, the water must be properly balanced, and the chlorine level must be adjusted to between 1-to-3 ppm free chlorine. More on adjusting water balance, and start-up chlorine levels, follows below.

## Steps to Prepare Water:

1. Calculate Pool Volume:  
See next section, below.
2. Adjust Water Chemistry:  
(Via saturation index... consider pH, total alkalinity, hardness, and water temperature; also adjust stabilizer level). See Reference section, pages 33 & 34.
3. Add Initial Chlorine Dosage:  
Use liquid chlorine (sodium hypochlorite), as obtained from pool supply center, to achieve 1-3 ppm free chlorine.
4. Add salt to water (test the water for salt level, first).  
Adjust to 3000 - 3500 ppm. See salt chart on page-32.
5. Enter pool volume Information into control center:  
See “Pool Volume” programming on page-27.

## Calculating Pool Volume:

$$\text{Average Depth} = \frac{\text{depth of deep end} + \text{depth of shallow end}}{2}$$

Gallons (pool size measured in feet)

Rectangular = Length x Width x Average Depth x 7.5

Round = Diameter x Diameter x Average Depth x 5.9

Oval = Length x Width x Average Depth x 5.9

Liters (pool size measured in meters)

Rectangular = Length x Width x Average Depth x 1000

Round = Diameter x Diameter x Average Depth x 785

Oval = Length x Width x Average Depth x 785

Calculated pool volume is: \_\_\_\_\_

*Enter Pool Volume figure in the information section, page-4.*

# PREPARING THE POOL WATER

## Adding Salt:

### Type of Salt to Add...

It is important to use Sodium Chloride (NaCl) salt that is greater than 99% pure. Acceptable types of salt include granular food grade, water softener pellets, or solar salt flakes; these are usually available in 25-lb to 80-lb bags at local pool or building supply outlets. Water softener and solar salt will have a slower dissolve rate than food grade salt. Rock salt and Granular Salt with Iodine or Rust Preventatives should not be used, as these mixtures contain high levels of impurities and will cause staining.

#### Note:

While not recommended, granular salt containing anti-caking additives such as YPS (Yellow Prussiate of Soda) or Sodium Ferrocyanide *can* be used. However, these mixtures—if not mixed and dissolved immediately— may cause a localized tint to the water or yellow staining of the pool/spa finish.

### Determine Amount of Salt Required (and salt level to maintain)...

*FIRST... Test the water for current salt content !!!*

The ideal salt range is 3000 - 3500 PPM (2500 minimum) (2.5 - 3.5 g/l). However, if so desired, the Digital Nano *can* operate with salt levels in excess of 35,000 PPM (35.0 g/l). Salt levels above 6000 PPM are not normally recommended, as corrosion issues may result. Salt levels below 2400 ppm will reduce the efficiency of the Digital Nano, and will result in low chlorine production. Extremely low salt levels (below 1900 ppm) will activate the low salt safety cut off, and will halt chlorine production until salt is replenished to proper levels. Once the Digital Nano is programmed to the pool water volume, the controller will automatically indicate how much salt is required to attain ideal salt levels. Additionally, please see the reference table, on page-32 for information on amount of salt to be added relative to the gallons of water to be treated vs. existing salt level.

## **CAUTION !**

Failure to heed the following may result in equipment damage.

Do not use a pool cleaner or vacuum head with wheels, as wheels can leave track marks on newly-plastered pools. Do not allow Granular salt to pile up in one location, without brushing, as staining may occur.

### Add Salt to Pool Water...

How to add the salt (or remove it if too much)...

The object is to have the salt fully dissolve into the water.

Start the water circulation pump and set to operate in continuous mode (24/7). Add salt directly to pool (or spa, if a spa-only installation), and over the main drain (If main drain is present). If there is no main drain, a vacuum head may be used to encourage salt circulation. Distributing the salt through brushing is also helpful; brush the salt toward the main drain (if one is present). Set pump operation to normal run time after salt has fully dissolved into water.

If the salt level becomes undesirably high, the only way to remove excess salt is to partially drain the pool/spa and refill with fresh water.

# MENU OVERVIEW

## ACCESS TO PROGRAMMING

### Control Panel:

The first line of the display typically indicates Purifier Output Level in percent (set to 50% at install), or whether the system is in Boost or Super-Boost mode. The second line displays temperature in Fahrenheit or Celsius and purifier on/off mode. A small dot in bottom right corner indicates the self-cleaning forward/reverse cycle.

### Operation of Buttons:

Press the **UP** or **DOWN** arrow to:

- Set Chlorine Level %\*
- Scroll through Menus and sub-Menus
- Increase or Decrease programming values for menus.

\*MAKE INITIAL SETTING AT INSTALL 50%.

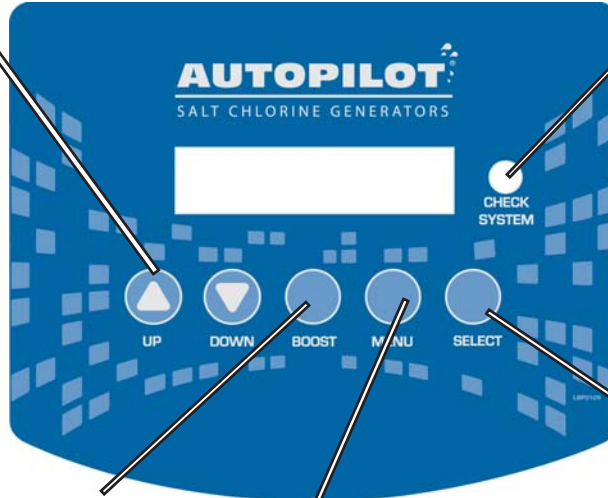

**CHECK SYSTEM** – Red LED flashes to warn attention is required. A warning message will also be displayed. If enabled, an audible alarm\* may also be heard when the system light is flashing.

\*SEE PAGE-29 FOR AUDIBLE ALARM ENABLE - DISABLE INSTRUCTIONS.

Press the **SELECT** button to choose the item currently displayed.

Press **BOOST** to start 24-hour boost mode, or press and hold **BOOST** for 8-seconds to start 72-hour boost mode. Press **BOOST** again to cancel boost.

Press **MENU** to leave normal operation to access the menus for programming and diagnostics.

### Menus:

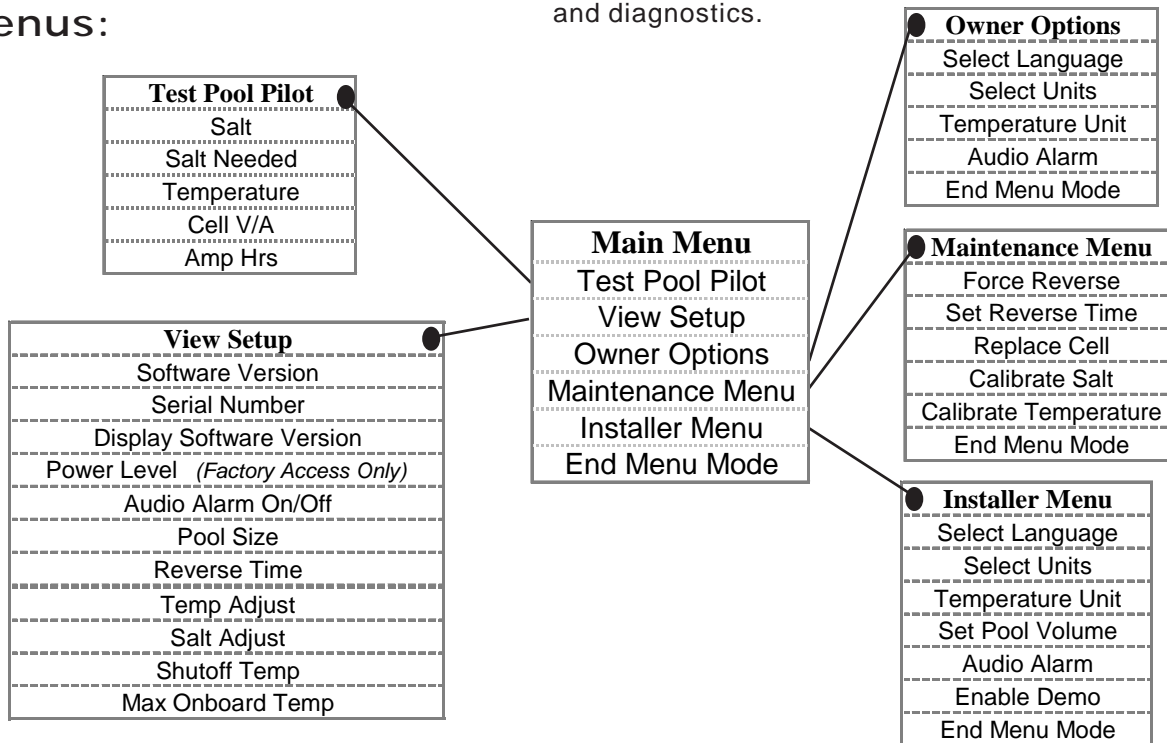



# PROGRAMMING

## ***Menu Button...***

The MENU button is used to leave the normal operation mode and enter the program and diagnostic modes. Use the UP/DOWN arrows and SELECT buttons to navigate through the menus and sub-menus.

MAIN MENU:

- Test Pool Pilot - displays various operating parameters and diagnostic results
- View Setup - displays the programmed setup parameters
- Owner Options - programs the primary operating parameters an owner would need to change
- Maintenance Menu - tests and programs the primary features a service technician would need to access when servicing the system
- Installer Menu - program the initial system setup

*Note: to permit quick access to features, some functions are accessed or programmed in several menus.*

## ***Select Button...***

The SELECT button chooses the displayed menu option. For the **Installer Menu**, press and hold the SELECT button for approximately 13-seconds to access this feature. The SELECT button also temporarily disables the buzzer during an error display.

## ***View setup...***

(Program and parameter menu to view the current programmed settings).

1. Press MENU, press **▼** or **▲** until "View Setup" is displayed, then press SELECT.
2. The display will automatically toggle through the following displays (or pressing **▼** or **▲** allows manual control forward and back. While in this feature, pressing MENU will override the remaining displays and exit back to normal operation):
  - "Software V X.Xx" (The version number of Nano #75040 or #75041 software)
  - "Serial #"
  - "Display V X.X.X.X ( The version number of Display software)
  - "Power Level" (Factory access only)
  - "Audio Alarm On/Off"
  - "XX,XXX gallons( liters)" (The pool volume programmed in Installation Menu; 15,000 is the factory setting; page-27)
  - "Reverse = X hrs" (The reverse rate programmed in Installation Menu: 4-hrs is factory setting; page-28)
  - "Temp. adjust = X" (The temperature adjustment variation of actual tri-sensor reading; page-28)
  - "Salt adjust  $\pm$  X %" (The salt calibration adjustment variation of actual tri-sensor reading; page-27)
  - "Logging" (only appears if logging feature is enabled)
  - "Shutoff Temperature" (Internal temperature of the unit at which it goes into a 5-minute cool-down period.
  - "Max Temp" (Maximum internal temperature reached)
3. The unit will automatically leave the menu and revert to normal operation.

# PROGRAMMING

## Programming at Installation:

To enter the **Installer Menu**, press and hold **SELECT** button for approximately 13-seconds.

Enter the Installer Menu and program: "**Set Pool Volume**" for specific pool. In addition, the Installer Menu contains other programmable preferences including: "Select Language," "Select Units," "Temperature Units," and "Audio Alarm"; configure these additional features, if necessary, for site-specific requirements.

NOTE: The Digital Nano requires the pool volume be entered into the microprocessor for the control center to automatically indicate how many pounds (kgs) of salt to add should salt levels fall. For instructions in calculating volume, see Calculating Pool Volume on page-23. The salt chart on page-32 can also be used to calculate how much salt, in pounds (kgs), should be added to reach the recommended level of 3000 ppm (3.0 g/l) salinity. **Adjust Purifier Output to 50%...** see page-30 for instructions.

## Review of Installer, Owner, & Maintenance Menu Programming:

NOTE: Once determined to be appropriately programmed for the installation site, the following menu items should not require regular access; rather, need to access should be infrequent or not at all. See page-29: "Basic Operational Programming," for setting initial Purifier Level and routine control instructions.

### Pool Volume:

(Must be programmed for the "salt amount needed" display to be accurate.)

1. Press MENU, press **▼** or **▲** until "**Installer Menu**" is displayed; then press and hold SELECT for 13-seconds.
2. Press **▼** or **▲** until "Set Pool Volume" is displayed; then press SELECT.  
(Factory setting is 15,000 gallons).  
(The range is 500 to 127,500 gallons (1,000 to 226,000 liters))
3. Press **▼** or **▲** until correct pool size is displayed; then press SELECT.
4. Press **▼** or **▲** until "End Menu Mode" is displayed; then press SELECT.

### Calibrating Salt:

**Note:** The unit has been calibrated at the factory and should not require further adjustments. In the event the salt display does not match on-site test results, follow these steps (it is necessary to wait 2-minutes after start-up before calibrating salt):

1. Press MENU, press **▼** or **▲** until "**Maintenance Menu**" is displayed; then press SELECT.
2. Press **▼** or **▲** until "Calibrate Salt" is displayed; then press SELECT.
3. Press **▼** or **▲** until the number on the display matches the accurately measured pool sample; then press SELECT. The maximum adjustment is  $\pm 1000$  ppm (1.0 g/l).
4. Press **▼** or **▲** until "End Menu Mode" is displayed; then press SELECT.

### Select Language:

(Allows for personal preference language display)

1. Press MENU, press **▼** or **▲** until "**Owner or Installer Menu**" is displayed; then press SELECT.
2. Press **▼** or **▲** until "Select Language" is displayed; then press SELECT (*English* is the factory setting).
3. Press **▼** or **▲** until desired language "*English*," "*Idioma Espanol*," or "*Langue Francais*," is displayed; then press SELECT.
4. Press **▼** or **▲** until "End Menu Mode" is displayed; then press SELECT.

# PROGRAMMING

## Calibrating Temperature:

Note: Temperature can only be calibrated 2-minutes after start-up.

(Used only when it is desired to match the display of the Digital Nano to another on-site thermometer.)

1. Press MENU; press  $\nabla$  or  $\Delta$  until "**Maintenance Menu**" is displayed; then press SELECT.
2. Press  $\nabla$  or  $\Delta$  until "*Calibrate Temp.*" is displayed; then press SELECT.
3. Press  $\nabla$  or  $\Delta$  to adjust temperature up or down to the desired temperature; then press SELECT. The maximum adjustment is  $\pm 6^{\circ}\text{F}$  ( $\pm 3^{\circ}\text{C}$ ). (To maximize protection, only negative adjustments will be used to calculate freeze protection temperature.)
4. Press  $\nabla$  or  $\Delta$  until "*End Menu Mode*" is displayed; then press SELECT.

## Select Units:

(Used to program the operator's personal preferences for the liquid and weights measurement the Digital Nano will display.)

1. Press MENU, press  $\nabla$  or  $\Delta$  until "**Owner**" or "**Installer Menu**" is displayed; then press SELECT.
2. Press  $\nabla$  or  $\Delta$  until "*Select Units*" is displayed; then press SELECT ("*English Units*" is the factory setting).
3. Press  $\nabla$  or  $\Delta$  until desired measurement "*English Units*" (gallons and pounds), or "*Metric Units*" (liters and kilograms), is displayed; then press SELECT.
4. Press  $\nabla$  or  $\Delta$  until "*End Menu Mode*" is displayed; then press SELECT.

## Temperature:

(Used to set the personal preference (C or F) for temperature display.)

1. Press MENU; press  $\nabla$  or  $\Delta$  until "**Owner**" or "**Installer Menu**" is displayed; then press SELECT.
2. Press  $\nabla$  or  $\Delta$  until "*Temperature Unit*" is displayed; then press SELECT ("*Fahrenheit*" is the factory setting).
3. Press  $\nabla$  or  $\Delta$  until desired measurement unit "*Fahrenheit*" or "*Celsius*" is displayed; then press SELECT.
4. Press  $\nabla$  or  $\Delta$  until "*End Menu Mode*" is displayed; then press SELECT.

## Set Reverse Time:

(Used to program the SuperCell's self-cleaning cycle.)

1. Press MENU, press  $\nabla$  or  $\Delta$  until "**Maintenance Menu**" is displayed; then press SELECT.
2. Press  $\nabla$  or  $\Delta$  until "*Set Reverse Time*" is displayed; then press SELECT (4-hours is the factory setting).
3. Press  $\nabla$  or  $\Delta$  until the desired cycle time (2, 4, 8, or 16 hours) is displayed; then press SELECT.
4. Press  $\nabla$  or  $\Delta$  until "*End Menu Mode*" is displayed; then press SELECT.

Continued Next Page...

## CAUTION !

Failure to heed the following may result in equipment damage.

Reduced polarity reversing cycle times will reduce SuperCell life, and should only be used due to uncontrollable scale formation on the Cell. ALWAYS test and adjust water balance, before attempting scale control via shortening reverse period.

# PROGRAMMING

## **Force Reverse:**

Note: this is a diagnostic tool, only, and should not be used unless a problem is suspected.

(Programming the SuperCell to activate a force reverse cycle, to verify if the system is reversing polarity (self cleaning)). There will be a 40-second delay, after selecting “*End Menu Mode*,” before reversing takes place.

1. Press MENU; press ▼ or ▲ until “**Maintenance Menu**” is displayed; then press SELECT.
2. Press ▼ or ▲ until “*Force Reverse*” is displayed; then press SELECT.
3. “Cell reversing” will display temporarily in 40-seconds.
4. Press ▼ or ▲ until “*End Menu Mode*” is displayed; then press SELECT.
5. The “.”(period) on the end of 2<sup>nd</sup> line of the display will either appear, or disappear—based on its previous state—to indicate cell power polarity has reversed.

## **Audible Alarm:**

Note: if alarm is due to low, or no water flow, audible alarm will automatically silence in 10-minutes. Upon restoration of flow, normal audible alarm operation will resume.

(To Enable or Disable the Audio Alarm)

1. Press MENU; press ▼ or ▲ until “**Owner**” or “**Installer**” Menu is displayed; then press SELECT.
2. Press ▼ or ▲ until “*Audio Alarm*” is displayed; then press SELECT.
3. Press ▼ or ▲ until “*On -or- Off*” is displayed; then press SELECT.

## **Basic Operational Programming:**

### ***Adjusting the Purifier Output % ...***

Press the UP/DOWN arrow buttons to enter the Purifier Adjustment mode. Adjust the purifier output percentage to the desired output: from 0% (off) to 100 % (maximum output); then, press SELECT to default back to the normal display. **At start up of a new system, the standard output setting starting point is 50%.**

Typically, once the initial setting is established, very little adjustment is needed. The purifier % setting refers to the amount of time the cell is energized within a 15-minute cycle. The system cycles on-and-off, as indicated on the display's lower right display.... “ON,” when generating chlorine. Higher settings will generate more chlorine.

Follow the instructions in the chart on next page to determine and correct purifier % settings.

Example:

50% setting = 50% of 15-minutes or 7.5-minutes ON and 7.5-minutes OFF.

25% setting = 3.75-min ON, 11.25-min OFF

Once the percentage is set, the unit will implement the temperature compensation algorithm based on current water temperature.

### ***Boost or SuperBoost...***

The Boost feature is used to increase the purifier % from its normal setting to 100% for a cumulative 24-hour or 72-hour period. When the Boost period expires, or is manually terminated, the Purifier % returns to its previous setting and normal operation.

- **Boost Purifier Output to 100% for 24-Hours...** From the normal operation mode, press and release the BOOST button. The display will flash: “*Boost 24-hour ON*,” then “*Boost hh*” (with the “hh” actually being the displayed hours remaining in the boost period).
- **Boost Purifier Output to 100% for 72-Hours...** From normal operation mode, press and hold the BOOST button until: “*Boost 72 hour ON*” is displayed; then release the BOOST button. Display will show: “*Boost*” for approximately 8-seconds, after that: “*Boost 72 hour ON*” will display; then, “*Boost hh*” (with the “hh” actually being the displayed hours remaining in boost period).

# PROGRAMMING

## Basic Operational Programming (continued):

### *Boost or SuperBoost (continued) ...*

When Boost is activated, and unit powered through an external time clock or programmer, the time remaining for the boost cycle is held in memory; Boost will continue when the pump restarts (until the 24 or 72-hr boost period has expired).

To exit Boost or SuperBoost mode and revert to normal operation:

- Allow the Boost cycle to expire.
- OR press BOOST at anytime to manually deactivate Boost.

## Control Options:

### *Purifier Mode*

The Control Unit normally runs in the manually-controlled purifier mode. In this mode, the Pool Pilot will automatically display informative messages about the condition of the chlorinator (Purifier Output %, water temperature, warning messages, etc.), and responds to manual adjustment of purifier % setting (as described below). The Digital Nano will revert to the normal display if there is no activity on the keypad for thirteen (13) or more seconds.

### **Purifier % Adjustment Procedure:**

- 1 Balance water chemistry according to necessary water chemistry parameters. (See pages 33 & 34.) For new start ups, if free chlorine level as tested is not at least 1 ppm, add liquid chlorine to insure a 1 -3 ppm free chlorine reading.
- 2 Add the proper amount of salt as indicated by the Digital Nano (or as described on page-32), and run the circulation pump continuously for 24-hours allowing the salt to be fully mixed and dissolved into the pool. *If the salt level is too low, the Digital Nano will provide a warning, and will not generate chlorine until the minimum salt level has been reached.*
- 3 Use the UP and DOWN arrow buttons to set the purifier % to 50%, and then allow the pool to operate normally.

For the first two weeks, test the water chemistry parameters every 3-4 days. Adjust chemicals as needed to maintain correct water balance. For the Free Chlorine adjustment, use the following table for fine-tuning the controller output percentage (%):

Purifier % currently set to:	If Free Chlorine is <u>lower</u> than ideal range...	If Free Chlorine is <u>higher</u> than ideal range...
<b>0% - 25%</b>	<p>The Purifier % output needs to be increased.</p> <p>Use the up arrow button to increase the Purifier Output %.</p>	<p>The Purifier % setting is too high.</p> <p>Use the up / down arrow button to lower Output. The Free Chlorine will need to be tested frequently and the Purifier Output % will need to be adjusted as needed to attain desired level.</p>
<b>25% - 100%</b>	<p>The Purifier % output needs to be increased.</p> <p>Use the up arrow button to increase the Purifier Output %</p>	<p>The Purifier % output needs to be decreased.</p> <p>Use the down arrow button to decrease the Purifier Output %</p>

After the optimal output percentage (%) has been determined, this setting will not normally require further adjustment. Rather, to compensate for increased bather usage or heavy rainfalls (which can both quickly consume chlorine), select a Boost Cycle.

# PROGRAMMING

## **Test Pool Pilot** (Diagnostic Menu):

- 1 Press MENU.
- 2 "*Test Pool Pilot*" is automatically displayed; then press SELECT.
- 3 The display will automatically toggle through the following displays (  $\nabla$  or  $\Delta$  allows manual control forward and back. While in this feature, pressing MENU will override the remaining displays and exit back to normal operation):
  - "*Salt =XXXX ppm (X.x g/l)*" (The optimum salt level is 3000 ppm (3.0 g/l))
  - "*Add Salt xx Lbs (xx Kg)*" (The amount of salt needed to maintain 3000 ppm (3.0 g/l))
  - "*Temperature XX° F (XX° C)*" (The temperature of the water flowing through the Tri-Sensor)
  - "*Cell = XX V XX.x A*" (The measured voltage and current sent to the SuperCell)
  - "*Amp-Hrs = xxxxxx*" (The amount of current times hours of operation received by the SuperCell)
4. The controller will automatically leave the menu and revert to normal operation.

END OF PROGRAMMING SECTION

# REFERENCE SECTION

## Salt Addition Chart:

The following salt chart is included for reference only; once programmed to the correct water volume, the controller will automatically indicate how much salt is required to achieve optimum water salinity. To use this chart:

1. Find current salt level (ppm or g/l) in the left column. (This can be obtained from Digital Nano display or by testing water.)
2. Find pool/spa volume in the second row (Gallons or Liters).
3. Find the amount of salt needed to bring pool to the ideal level by finding the intersection of the row and column.

For volumes other than what is shown, use combinations of various columns.

For example, for an 11,000 gallon (41,646 liter) pool with a salt level of 500-ppm (5 mg /l), the column value for 1000 gallons (4,000 liters) (21 pounds (9 kg)) is added to the column value for 10,000 gallons (38,000 liters) (209 pounds (95 kg)) which gives a total of 230 pounds (104 kg) of salt needed to bring your pool salt level up to the ideal level of 3000-ppm (3.0 g/l).

The salt is constantly recycled during normal operation. Loss of salt during a swimming season should be minimal. Filter backwashing, draining due to rain water overflow, splashing and bathing suit drag out, and leaks (excessive salt loss in a short span of time) are typical ways salt is lost. Salt does not leave the pool when water evaporates.

Pounds (kilograms) of Salt needed to attain 3000 ppm (3.0 g/l)

Current salt level ppm (g/l)	Pool/Spa Volume in Gallons or <i>Liters</i>									
	1,000 <i>4,000</i>	2,000 <i>8,000</i>	5,000 <i>18,000</i>	10,000 <i>38,000</i>	15,000 <i>56,000</i>	20,000 <i>76,000</i>	25,000 <i>94,000</i>	30,000 <i>114,000</i>	35,000 <i>132,000</i>	40,000 <i>152,000</i>
0	25 <i>11</i>	50 <i>23</i>	125 <i>57</i>	250 <i>114</i>	376 <i>170</i>	501 <i>227</i>	626 <i>284</i>	751 <i>341</i>	876 <i>398</i>	1,002 <i>454</i>
250 <i>(0.25)</i>	23 <i>10</i>	46 <i>21</i>	115 <i>52</i>	230 <i>104</i>	344 <i>156</i>	459 <i>208</i>	574 <i>260</i>	689 <i>312</i>	803 <i>364</i>	918 <i>416</i>
500 <i>(0.50)</i>	21 <i>9</i>	42 <i>19</i>	104 <i>47</i>	209 <i>95</i>	313 <i>142</i>	417 <i>189</i>	522 <i>237</i>	626 <i>284</i>	730 <i>331</i>	835 <i>379</i>
750 <i>(0.75)</i>	19 <i>9</i>	38 <i>17</i>	94 <i>43</i>	188 <i>85</i>	282 <i>128</i>	376 <i>170</i>	470 <i>213</i>	563 <i>256</i>	657 <i>298</i>	751 <i>341</i>
1,000 <i>(1.0)</i>	17 <i>8</i>	33 <i>15</i>	83 <i>38</i>	167 <i>76</i>	250 <i>114</i>	334 <i>151</i>	417 <i>189</i>	501 <i>227</i>	584 <i>265</i>	668 <i>303</i>
1,250 <i>(1.25)</i>	15 <i>7</i>	29 <i>13</i>	73 <i>33</i>	146 <i>66</i>	219 <i>99</i>	292 <i>133</i>	365 <i>166</i>	438 <i>199</i>	511 <i>232</i>	584 <i>265</i>
1,500 <i>(1.5)</i>	13 <i>6</i>	25 <i>11</i>	63 <i>28</i>	125 <i>57</i>	188 <i>85</i>	250 <i>114</i>	313 <i>142</i>	376 <i>170</i>	438 <i>199</i>	501 <i>227</i>
1,750 <i>(1.75)</i>	10 <i>5</i>	21 <i>9</i>	52 <i>24</i>	104 <i>47</i>	157 <i>71</i>	209 <i>95</i>	261 <i>118</i>	313 <i>142</i>	365 <i>166</i>	417 <i>189</i>
2,000 <i>(2.0)</i>	8 <i>4</i>	17 <i>8</i>	42 <i>19</i>	83 <i>38</i>	125 <i>57</i>	167 <i>76</i>	209 <i>95</i>	250 <i>114</i>	292 <i>133</i>	334 <i>151</i>
2,250 <i>(2.25)</i>	6 <i>3</i>	13 <i>6</i>	31 <i>14</i>	63 <i>28</i>	94 <i>43</i>	125 <i>57</i>	157 <i>71</i>	188 <i>85</i>	219 <i>99</i>	250 <i>114</i>
2,500 <i>(2.5)</i>	4 <i>2</i>	8 <i>4</i>	21 <i>9</i>	42 <i>19</i>	63 <i>28</i>	83 <i>38</i>	104 <i>47</i>	125 <i>57</i>	146 <i>66</i>	167 <i>76</i>
3,000 <i>(3.0)</i>	Ideal									
3,500 <i>(3.5)</i>	OK for DIG-220 Operation - (This is typically the maximum salt level desired by most pool owners/operators since most people can taste salt levels above this.)									
Greater than 3,500	OK for DIG-220 Operation but greater than 6000 ppm can cause corrosion to metallic objects (If lower salt level is desired, partially drain and refill with fresh water.)									

# REFERENCE SECTION

## Basic Water Chemistry:

The Digital Nano unit is designed to produce chlorine on a daily basis. To monitor the system's efficiency, the water chemistry ranges, and schedule of periodic checks—per below—should be followed.

<b>CAUTION !</b>	Failure to heed the following may result in equipment damage.
Excessively high chlorine levels can cause premature cell failure and corrosion damage to pool fixtures and equipment.	

<b>CAUTION !</b>	Failure to heed the following may result in equipment damage.
Always follow the instructions on the manufacturer's label whenever handling or using chemicals.	

CHEMICAL or FACTOR	IDEAL RANGE	IDEAL TEST SCHEDULE	EFFECT OF LOW/HIGH LEVELS	CORRECTIVE ACTIONS
<b>Free Chlorine</b>	1 to 3 ppm	Weekly	<p><u>Low free chlorine:</u> Not enough residual chlorine to safely sanitize pool water.</p> <p><u>High free chlorine:</u> Corrosive to metallic fixtures in pool water. Can bleach swimwear and hair.</p>	<p><u>Low free chlorine:</u> Check for combined chlorine level and shock as necessary. Increase purifier output to maintain a 1-3 ppm residual reading.</p> <p><u>High free chlorine:</u> Decrease purifier output. Let chlorine dissipate normally until 1-3 ppm is achieved. In extreme cases, pool water can be diluted with fresh water or a chlorine neutralizer added. (Diluting will reduce salt and CYA. Check and adjust as needed.)</p>
<b>pH</b>	7.2 to 7.8 ppm	Weekly	<p><u>Low pH:</u> (acidic) Equipment corrosion, eye/skin irritation, plaster etching, rapid chlorine consumption</p> <p><u>High pH:</u> (basic) Scale formation, cloudy water, eye/skin irritation, poor chlorine effectiveness</p>	<p><u>Low pH:</u> Add sodium carbonate or soda ash</p> <p><u>High pH:</u> Add muriatic acid or sodium bisulfate.</p>
<b>Total Alkalinity</b>	80 to 100 ppm	Monthly	<p><u>Low TA:</u> Eye irritation, pH "bounce", stained/etched plaster and metal corrosion.</p> <p><u>High TA:</u> Constant acid demand, difficulty in maintaining pH, and contributes to scale formation or cloudy water conditions.</p>	<p><u>Low TA:</u> Add sodium bicarbonate.</p> <p><u>High TA:</u> Add muriatic acid often, a little at a time (may take a week or more to lower the TA).</p>
<b>Salt</b>	3000 to 3500 ppm	Monthly	<p><u>Low Salt:</u> Below 2,500 ppm causes premature cell failure and reduces chlorine production</p> <p><u>High Salt:</u> Above 6,000 ppm can cause corrosion of metallic fixtures and will taste salty. Note: Cubby can safely operate with salt levels up to 35,000.</p>	<p><u>Low Salt:</u> Add salt according to digital display on Pool Pilot unit or salt chart.</p> <p><u>High Salt:</u> If undesirably high, partially drain and refill the pool with fresh water. (Diluting will reduce CYA. Check and adjust as needed.)</p>
<b>Calcium Hardness</b>	200 to 400 ppm	Monthly	<p><u>Low CH:</u> Etching of plaster, equipment corrosion</p> <p><u>High CH:</u> Scale formation, cloudy water. Rapid buildup of scale may exceed the system's self-cleaning capability and require manual cleaning of the SuperCell.</p>	<p><u>Low CH:</u> Add calcium chloride flakes.</p> <p><u>High CH:</u> Partially drain and refill pool with fresh water to dilute. (Diluting will reduce salt and CYA. Check and adjust as needed.)</p>
<b>Cyanuric Acid (CYA) - Stabilizer</b>	60 to 80 ppm <i>Outdoors</i>  30 to 50 ppm <i>Indoors or Colder Climates</i>	Monthly	<p><u>Low CYA:</u> destruction of chlorine by the UV rays from the sun.</p> <p><u>High CYA:</u> Requires more chlorine to maintain proper sanitizer levels. <b>Note: CYA not needed for indoor or bromine pools.</b> CYA can be reduced to 30 - 50 ppm for Cubby Digital in colder climate regions.</p>	<p><u>Low CYA:</u> Add cyanuric acid (1 lb/5000 gallons increases CYA 25 ppm)</p> <p><u>High CYA:</u> Partially drain and refill pool with fresh water to dilute. (Diluting will reduce salt. Check and adjust as needed.)</p>



# REFERENCE SECTION

## Using the Saturation Index (SI):

The Saturation Index is a formula used to predict the calcium carbonate saturation of water, that is, whether your water will precipitate, dissolve, or be in equilibrium with calcium carbonate.

Water is properly balanced if the SI is  $0 \pm 0.3$ . If SI is greater than 0.3, scaling and staining will occur. If SI is less than -0.3, then the water is corrosive to metallic fixtures and aggressive to plaster surfaces and vinyl liners.

A high or low SI can cause premature damage to the cell, equipment or pool finish. As a general rule, higher concentrations of calcium, total dissolved solids, pH, and alkalinity all promote a greater tendency for scale. Scaling potential also increases with increasing temperature.

Use the chart below to determine your overall water balance. Test water for pH, water temperature, Calcium Hardness, Total Alkalinity, Salt Level, and use the equivalent Factors (TF, CF, AF, Constant) from the chart below to determine your Saturation Index. Adjust chemicals to maintain balanced water.

$$\text{pH} + \text{TF} + \text{CF} + \text{AF} - \text{SC} = \text{SI}$$

Temperature		TF	Calcium Hardness	CF	Total Alkalinity	AF	Salt Level	SC
60 F	15.6C	0.4	150 ppm	1.8	75 ppm	1.9	0 - 1000 ppm	12.1
66 F	18.9C	0.5	200 ppm	1.9	100 ppm	2.0	1001 - 2000 ppm	12.2
76 F	24.4C	0.6	250 ppm	2.0	125 ppm	2.1	2001 - 3000 ppm	12.3
84 F	28.9C	0.7	300 ppm	2.1	150 ppm	2.2	3001 - 4000 ppm	12.4
94 F	34.4C	0.8	400 ppm	2.2	200 ppm	2.3	4001 - 5000 ppm	12.5
103 F	39.4C	0.9	600 ppm	2.4	250 ppm	2.4	5001 - 6000 ppm	12.6

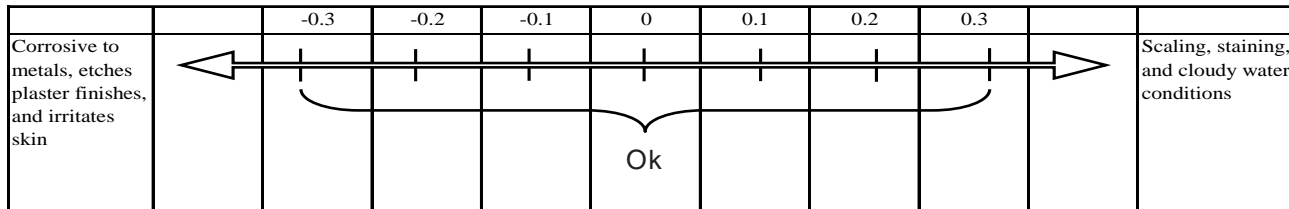

### Examples:

#### Water Test Results #1

pH = 7.4 .....: pH = 7.4  
 Water Temperature = 84 F .....: TF = 0.7  
 Calcium Hardness = 400 ppm .....: CF = 2.2  
 Total Alkalinity = 125 ppm .....: AF = 2.1  
 Salt Level = 3000 ppm .....: SC = 12.4

$7.4 + 0.7 + 2.2 + 2.1 - 12.4 = 0$   
 (Water is perfectly balanced)

#### Water Test Results #2

pH = 7.8 .....: pH = 7.8  
 Water Temperature = 84 F.....: TF = 0.7  
 Calcium Hardness = 600 ppm .....: CF = 2.4  
 Total Alkalinity = 200 ppm .....: AF = 2.3  
 Salt Level = 3000 ppm .....: SC = 12.4

$7.8 + 0.7 + 2.4 + 2.3 - 12.4 = 0.8$   
 (Water is scale forming)

# MAINTENANCE

## Fuse Location and Ratings:

To inspect or service fuse, disconnect power and remove power center cover (see below for location of fuse). As required, see the wiring diagram on the inside cover of the Digital Nano unit for information on converting the unit from a 110-VAC to 230-VAC input power supply.

Board	Location	Fuse Specification	Description
Main Power Board 75040	F1	250 Vac 2 Amp Slow Blow	Main AC Power Fuse
Main Power Board 75041	F1	250 Vac 1 Amp Slow Blow	Main AC Power Fuse

## WARNING !

Failure to heed the following may result in permanent injury or death.

**ELECTRICAL SHOCK HAZARD...** Turn off the electrical power to unit before servicing.

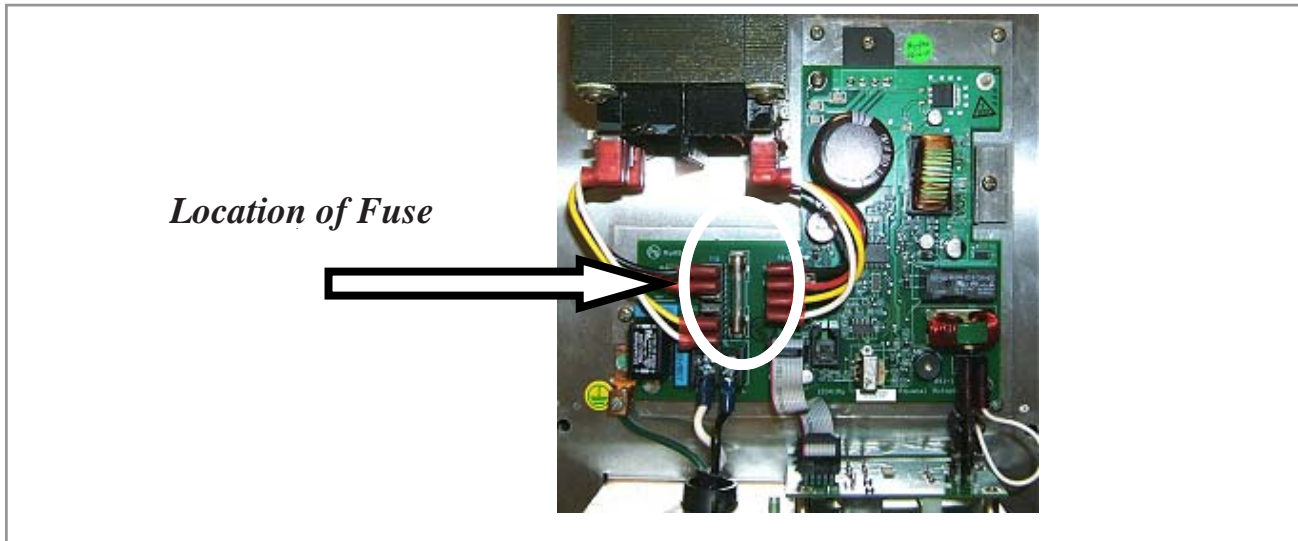

## Tri-Sensor Assembly:

The Tri-Sensor Assembly is used to measure water flow, salt level, and water temperature.

*Note: The use of high strength magnet devices in the close proximity of the Tri-Sensor can cause the flow switch to function incorrectly.*

When the water flow reaches a minimum flow rate of 20-gpm (76 L/m), the flow paddle magnet closes a micro-switch monitored by the Control Unit.

The Control Unit uses dedicated salt sensor blades to measure the level of salt in the water.

The Control Unit uses the temperature sensor to determine water temperature. This measurement is required for the Patented Automatic Temperature Compensation feature to automatically adjust chlorine output as water temperature varies. Less chlorine is needed in cold water, so chlorine output is automatically reduced as water temperature drops (avoiding excess chlorine production). Conversely, more chlorine is needed in warmer water, and production is automatically adjusted higher as water temperatures increase.

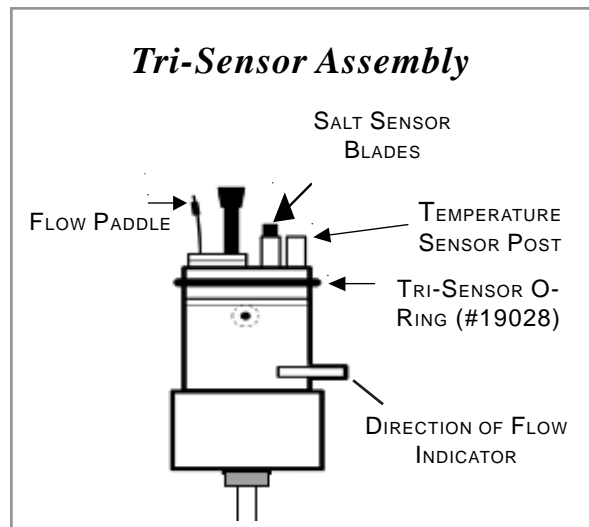

# MAINTENANCE

## Removing\Inspecting\Cleaning the Tri-Sensor (Pump must be off):

Note: the Tri-Sensor does not normally require maintenance or cleaning.

1. Disconnect the Tri-Sensor cable from the power center.
2. Remove the two (2) screws retaining the Tri-Sensor in the Tee joint of the Manifold.
3. Note the orientation of the Directional of Flow Tab. The Tri-Sensor must be installed in the same orientation when it is reinstalled or replaced.
4. The Tri-Sensor can now be pulled out of the Tee. Firmly grip the Tri-Sensor assembly (this is typically done with a large pair of channel lock pliers). Twist the Tri-Sensor back-and-forth while simultaneously pulling the Tri-Sensor straight out of the Tee joint.

### **CAUTION !**

Failure to heed the following may result in equipment damage.

The Tri-Sensor should not be pulled out at an angle, or the flow paddle or flow post may be damaged.

5. Inspect the following on the flow switch: verify the thin metallic paddle is straight and free from erosion; verify the plastic post is straight and free of cracks. Do not twist or bend the paddle or the plastic post.
6. Inspect the two salt sensor blades. The blades should not have any mineral deposits (scale) or other debris on them. If the blades need to be cleaned, use the following method:
  - Do not use any metallic objects to scrape the blade surfaces or you will remove or damage the blade sensor coating.
  - To remove a calcium scale buildup, mix one (1) part Muriatic Acid into four (4) parts water. Mix the solution in a small container tall enough to cover the sensor blades.

### **WARNING !**

Failure to heed the following may result in permanent injury or death.

**CHEMICAL HAZARD...** To avoid damaging splashes, always add acid to water, never water to acid. Wear safety glasses and use other appropriate personal protection equipment.

- Immerse the salt sensor blades in the solution for up to 15-minutes. An effervescing action indicates the calcium is being dissolved from the blades.
  - Rinse with fresh water and reinspect. Repeat the acid treatment as necessary until all scale has been eliminated.
7. Check the tri-sensor assembly for any damage to the plastic housing and replace if needed.

# MAINTENANCE

## Testing the Flow Switch, Cleaning the Filter Screen, Cleaning the Bypass Valve (for optional 94105 Manifold)

The flow switch is a critical equipment protection device. When water flow has stopped, to prevent damage to the cell or system, it is important power to the SuperCell be automatically turned OFF. It is important to verify the proper operation of the Tri-Sensor's water Flow Switch protection device. **CAUTION: Do NOT operate system with a faulty flow switch.** The following procedure can be used to verify the proper operation of the flow switch, or to flush debris from the Bypass Valve.

1. Turn off circulator pump.
2. Slightly loosen the union nut just below the cell on the side of the manifold that does not contain the filter screen.
3. Completely loosen the manifold union nut that contains the filter screen and pivot the manifold to gain access to the filter screen.
4. Remove the screen. Clean the screen if dirty.
5. If the screen was dirty, then the system may need to be purged to remove excess debris. Leave the manifold off and run the pump for a few seconds until clear.
6. Wrap the strainer screen securely with a small piece of plastic wrap (saran wrap, food wrap or zip lock bag) as indicated in the diagram, place it back in the union.
7. Tighten the two unions that were loosened.
8. Turn on the pump and the Digital Nano. The plastic will stop water flow to the flow switch, which is part of the Tri-Sensor that is located in the upper portion of the manifold. All water will be forced through the Bypass Valve. This action will normally flush out any small bits of debris trapped in the Bypass Valve.)
9. The Control Unit should detect a low water flow at the Tri-Sensor, and activate the red Check System LED. The Control Unit will also display the message "Purifier Off! Check Flow."
10. If the Control Unit did not display this warning, then check the Tri-Sensor cable connections and inspect and clean the Tri-Sensor as outlined in the previous section. If the warning message still does not appear, then turn the Pool Pilot off and contact the factory or your local dealer for assistance. **CAUTION: Do NOT operate system with a faulty water flow switch.**
11. Turn the pump off.
12. Loosen the unions.
13. Remove the plastic wrap and replace the strainer screen.
14. Resume normal operation.

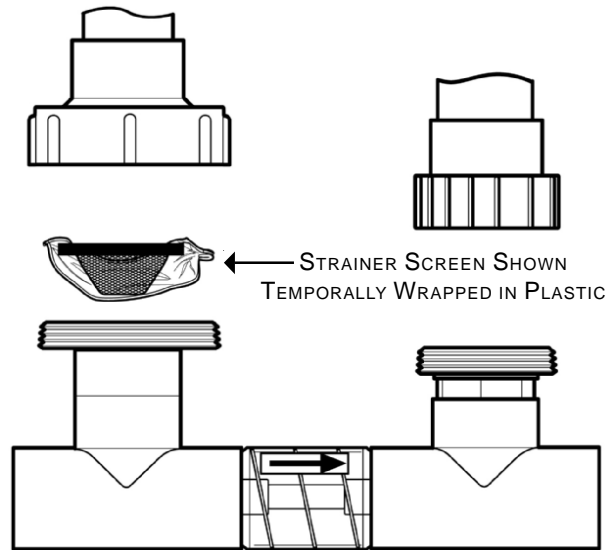

# MAINTENANCE

## Servicing the SuperCell

**REMEMBER:** the Nano Digital system is to be used ONLY with an RC-35/22 cell. Use of any other cell may cause equipment damage and void warranty.

The SuperCell may require removal for periodic visual inspections, or for servicing when debris or calcium mineral deposits develop. The need to inspect and service the cell is indicated by any of the following display messages: "Check System" light, and the message, "Low Flow; Purifier OFF" or "Check Cell / Clean Cell."

### ***Removal of the SuperCell...***

The SuperCell is installed with Unions on each end to allow quick and easy installation and removal.

1. Turn off pump and shut off all power.
2. Detach the SuperCell cable from the SuperCell.
3. Unscrew the unions at both ends of the SuperCell.
4. Slide the SuperCell out of the Manifold Assembly.

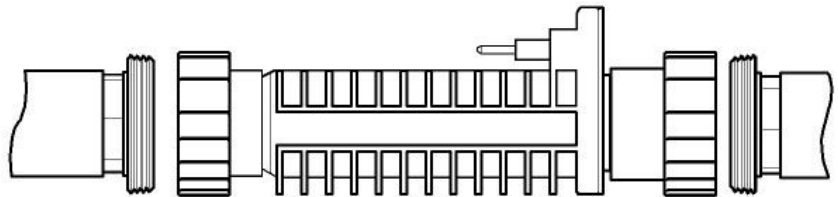

SUPERCELL AND UNIONS – (SIDE VIEW)

### ***Visual Inspection of the SuperCell...***

Remove the SuperCell from the Manifold Assembly, following the directions in the previous section. The SuperCell titanium blades, seen inside the cell body, should be straight and clear of any debris on the ends or between the blades.

A white flaky or crusty calcium build up on the edge or between the blades will shorten the life of the cell.

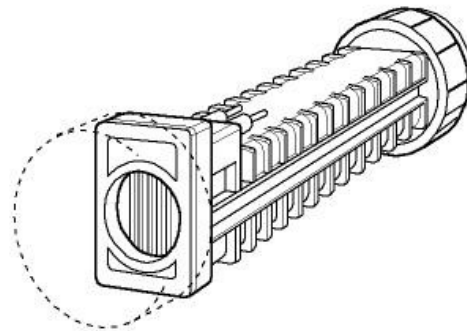

END VIEW OF THE SUPERCELL  
LOOKING AT THE BLADES

Clean the cell immediately, and determine the cause of scaling. See "Basic Water Chemistry," and "Using the Saturation Index" ... on pages 33 & 34. Also see "Manual Cleaning of the SuperCell" ... on the next page.

Your *Nano* is designed to automatically self-clean calcium scale build up that may form on the blades during normal operation. However, unbalanced water chemistry can cause a heavy scale build up exceeding self-cleaning capabilities... thus; periodic manual cleaning may be necessary. The simplest way to avoid this extra work is to maintain the water chemistry at the levels recommended.

## **CAUTION !**

Failure to heed the following may result in equipment damage.

For maximum cell life, maintain water in a balanced condition. Water maintained in a scaling condition will shorten cell life and may render the chlorinator inoperative. Damage and/or service calls, caused by improper water balance, will NOT be covered under the equipment warranty.

# MAINTENANCE

## Inspecting SuperCell (continued):

### *Manual Cleaning of the SuperCell...*

#### **CAUTION !**

Failure to heed the following may result in equipment damage.

Scraping or scratching the titanium blade's edge or surface **will** damage the blade catalyst coating and cause premature failure of the cell... warranty will be voided. Never use any sharp or metallic objects to remove scale.

1. Turn off circulator pump.
2. Loosen the unions as indicated on the cell manifold.

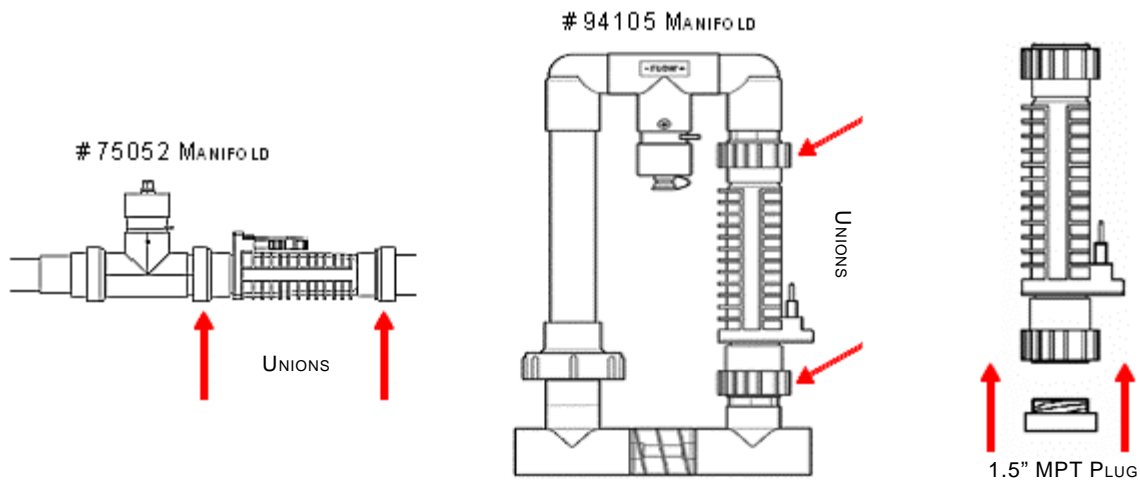

3. Remove the cell and place a cap or plug on the end of the cell as shown. Plugs are available at any pool supply warehouse or home improvement store. Ask for a 1.5" MPT clean out plug.

#### **WARNING !**

Failure to heed the following may result in permanent injury or death.

**CHEMICAL HAZARD...** To avoid damaging splashes, always add acid to water, never water to acid. Wear safety glasses and use other appropriate personal protection equipment.

4. Fill the capped cell with water 2-inches from the top of the cell blades.
5. Fill the rest of the cell with Muriatic Acid. This allows for an approximate 1-to-4 solution. Always add the acid to the water. If you do it the other way around, it can cause the solution to spray back at you causing serious injury.
6. Allow the solution to sit in the cell for up to 20-minutes.
7. Safely dispose of the solution; pouring it into the pool is recommended.
8. Remove the cap and rinse the cell with light water pressure; reinspect the cell, and repeat acid cleaning if the cell is still scaled.
9. Once the cell has been cleaned, dry off the cell electrical terminals; reassemble the manifold, and return the system to service. **CAUTION: The electrical terminals must be completely dry** to avoid corrosion and failure of the cell or cable.

# MAINTENANCE

## Inspecting SuperCell (continued):

### *Installing a SuperCell...*

1. Clean and dry the electrical terminals on the SuperCell. The contacts must be completely dry to avoid corrosion and failure of the SuperCell or cable.
2. Insure the union o-rings are firmly in place; then place the SuperCell into the manifold with the cell oriented as illustrated in the diagrams on page-18.
3. Tighten the unions by hand for a watertight seal.
4. The SuperCell will have two (2) electrical terminals.
5. The SuperCell cable has three (3) electrical contact terminals, the red weather plug will seal the unused contact in the cable. Position the SuperCell plug so the two (2) open holes align with the two mating terminals and push gently, but firmly, to connect.
6. Turn on the system.
7. Check for leaks and proper operation of the chlorinator.

## **Important Information Critical to the Survival of Your Chlorinator Winterizing**

### **CAUTION !**

Failure to heed the following may result in equipment damage.

Special measures are required in the event of freezing conditions. Your Pool Pilot may be damaged if measures are not taken in advance of freezing conditions. Equipment damage due to freezing conditions is NOT covered under the equipment warranty.

Just as pool plumbing will be, the Digital Manifold (including the SuperCell and Tri-Sensor) will be damaged by freezing water. In areas that experience severe cold weather, or extended periods of freezing temperatures, the system should be winterized by draining all water from the Manifold Assembly (SuperCell and Tri-Sensor), pump, filter, supply and return lines prior to freezing weather. The Control Unit is not affected by the cold and does not need to be removed.

### **Spring Start-Up**

It is recommended the water be manually chlorine-shocked when first starting up the pool in the springtime. Test water, and add the appropriate chemicals to balance the pool water per the levels recommended in on page-11. Be sure to check salt and cyanuric acid (stabilizer), bringing those readings up to the recommended levels. It is also a good idea to inspect the cell, manifold screen, and test the Tri-Sensor flow switch; clean and/or replace those items as necessary.

# TROUBLESHOOTING

Message Displayed	Problem	Typical Solution
Error Purifier off Check Flow	Chlorine generation has stopped due to insufficient water flow.	<ol style="list-style-type: none"> <li>1. Turn on the circulation pump.</li> <li>2. Turn the control valves to the correct position to allow water flow through the manifold.</li> <li>3. If a suction type vacuum cleaner is used, then clean if clogged.</li> <li>4. Check and clean the skimmer basket.</li> <li>5. Check and clean the pump basket.</li> <li>6. Check and clean or backwash the main circulation filter.</li> <li>7. Clean the manifold screen of trash or debris. For instructions to clean the screen, test the flow switch, , clean the bypass valve (on a bypass manifold only), see Maintenance section of manual.</li> <li>8. Verify that the Tri-Sensor cable is plugged in. Plug it in, using care to orient it correctly before inserting it. Clean the SuperCell if plugged with debris or calcium scale (See Maintenance section of manual.)</li> <li>9. Check for air in the bypass manifold by loosening the top union on the cell to see if air or water comes out. If air comes out then there may be a vacuum side leak or the pump may be under sized. Check for leak at pump basket O-ring, leaking valve or fitting.</li> <li>10. If the pump is a 2-speed pump, is it on low speed? The low speed may not create enough flow for the manifold.</li> </ol>
Error Purifier off Add Salt xxx lbs	Chlorine generation has stopped because the salt level is below 1900 ppm (which is too low).	Add salt as indicated on the Nano display to bring the salt level up to 3000 ppm (3.0 g/l).
Warning! Add Salt xxx lbs	The salt level is between 2000-2400 ppm (which is too low).	Add salt as indicated on the Nano display to bring the salt level up to 3000 ppm (3.0 g/l).
Error Purifier off Add Salt xxx lbs or Warning! Add Salt xxx lbs	Added salt as indicated by the Digital Nano, but salt level still shows low.	<ol style="list-style-type: none"> <li>1. The pool volume has not been set up in the Installer Menu and is higher than the factory default of 15,000 gallons (56,000 liters).</li> <li>2. The salt sensor in the Tri-Sensor may be dirty.</li> <li>3. The Salt display may need to be calibrated.</li> </ol>
<i>No Error Displays</i>	Salt level on display does not match pool store or salt test strip.	<ol style="list-style-type: none"> <li>1. The test may have been faulty or the salt strips may be old or damaged. Have salt level rechecked at local pool store.</li> <li>2. If the discrepancy is more than 400 ppm (4 mg/l), then contact AutoPilot Systems. If the Tri-Sensor salt blades are clean, then the salt sensor may need to be re-calibrated.</li> </ol>
Warning! Check /Clean Cell	Conductivity of the water is reduced and is usually caused by low salt, cold water, or a scaled cell.	<ol style="list-style-type: none"> <li>1. Check the salt level and adjust to 3000 ppm (3.0 g/l) or verify salt calibration.</li> <li>2. For water temperatures below 65°F (18.3°C), increase salt to 3500 ppm (3.5 g/l).</li> <li>3. Remove and inspect the cell for white calcium scale. (See cell inspection and cleaning instructions in the Maintenance section of manual.)</li> </ol>
	The salt level is below 2800 ppm (2.8 g/l) & temperature below 70°F (21°C).	Increase salt level to 3500 ppm or increase temperature on heater if applicable.
	The salt display differs from salt test.	Adjust salt display in the Salt Calibration mode. (See <i>Calibrating Salt</i> , in the Programming section of manual.)



# TROUBLESHOOTING

Message Displayed	Problem	Typical Solution
Warning! Check /Clean Cell  <i>Continued from Previous Page</i>	The cell is scaled.	Determine frequency of scaling. <ul style="list-style-type: none"> <li>• ONE week or less = Power Supply not reversing polarity – contact factory.</li> <li>• TWO weeks or more = Water Chemistry related problem (See Reference section of manual, <i>Water Chemistry</i> and <i>Saturation Index</i> topics).</li> </ul> Adjust water chemistry or adjust “Set Reverse” to a shorter cycle.
	If this is a new installation...	Verify the incoming voltage matches the voltage of the Control Unit. (See Specifications and Installation sections of manual.)
Warning! Low Amps-Cell?	Cell is completely clogged from calcium scale, has failed, or the cell cord is loose or damaged.	1. Check cell for calcium scale buildup. Clean as needed. 2. Check for visual wear on the edges of the terminal blades. 3. Check the cell cord for tight connections on the cell and on the power supply. Check the plug for burns. Tighten or replace as needed. 4. Replace cell if depleted.
	The cell cord is disconnected	Verify cell cables are inserted fully into the Digital Nano base cell connector.
	The cell is heavily scaled.	Remove and acid wash as described in Maintenance section of manual.
	If this is a new installation...	Verify that the incoming voltage matches the voltage of the Control Unit. (See Specifications and Installation sections of manual.)
Warning! Low Amps-Cell?  Warning! Check/Clean Cell	Cell is not receiving the expected Amps.	Enter “Test Pool Pilot” mode through the menu. Write down the salt level, water temperature, and cell volts and amps. <ul style="list-style-type: none"> <li>• If the volts are 24-26, then the problem is usually caused by low salt, improperly connected, disconnected or loose cell cord, water less than 65°F (18.3°C), a scaled cell, or cell near end of life. Correct as appropriate.</li> <li>• If the volts are less than 20, then contact Autopilot Systems for assistance.</li> </ul> <u>Installer:</u> If the unit is configured for 230-VAC operation, then verify the input AC voltage is not 115-VAC. Supply correct voltage, or reconfigure the unit as appropriate.
Warning! Bad Temp Sensor?	Temperature is out of range.	1. Check the Tri-sensor cable; make sure it is not disconnected or loose. 2. Check the water temperature. 3. If confirmed temperature is OK, contact AquaCal AutoPilot for assistance.
Normal display	There are no warning messages on the display but the chlorine level is too low.  Water quality looks dirty or cloudy.	1. The chlorine setting has been fine, but a temporary boost of chlorine is needed to adjust for rain or a temporary bather increase. Press the Boost button to temporarily elevate the chlorine production level to 100% for 24-hrs. The chlorine output will revert to the original setting after 24-hrs. 2. The chlorine setting has been fine, but a temporary (or longer) SuperBoost of chlorine is needed to adjust for heavier rain or bather increase. Press and hold the Boost button for 8-seconds to temporarily elevate the chlorine production level to 100% for 72-hrs. The chlorine output will revert to the original setting after 72-hrs.

# TROUBLESHOOTING

Message Displayed	Problem	Typical Solution
<p style="transform: rotate(-45deg);">Continued from Previous Page</p>	<p>Normal display</p> <p>There are no warning messages on the display but the chlorine level is too low.</p> <p>Water quality looks dirty or cloudy.</p>	<ol style="list-style-type: none"> <li>3. Check pool chemistry parameters. (See <i>Water Balance &amp; Chemistry Recommendations</i> in the Owner's Quick Start section of manual.) The cyanuric acid level may be low and the chlorine is being consumed quickly by the UV from the sun.</li> <li>4. The chlorine output needs to be increased.                             <ul style="list-style-type: none"> <li>• Use the up arrow key to increase the chlorine output setting.</li> <li>• Increase the pump run time so the chlorinator is generating chlorine for a longer period of time.</li> </ul> </li> <li>5. Test water for high phosphate levels. Use a product such as LoChlor Starver to reduce phosphates if the phosphate level is higher than 22-ppm (22 mg/l).</li> <li>6. If the water temperature is 55°F (10°C) or colder, the Pool Pilot has automatically turned the Chlorine output down to 1% to avoid over-chlorination. Bacteria and algae activity is greatly reduced at these temperatures; so, this should not be a problem. Hand dose additional chlorine if necessary.</li> <li>7. Obtain an independent salt reading to check the Pool Pilot reading. Add salt, if needed, and re-calibrate the Pool Pilot salt display.</li> <li>8. Check the Max Temp in the setup menu. If higher than the Shutoff temp., unit may be going into a cooling mode. Shade, or relocate unit to an area less affected by direct sunlight or other sources of heat external to the unit.</li> </ol>
	<p>Normal display</p> <p>There are no warning messages on the display.</p> <p>The chlorine level is too low but the pool water looks fine.</p>	<ol style="list-style-type: none"> <li>1. The test kit reagents or strips may be old or have been exposed to sunlight. Replace the kit or reagents and retest.</li> <li>2. There is too much chlorine in the pool. The chlorine is bleaching the test kit reagents. Dilute the water sample with distilled water and retest. Lower the chlorine output setting with the down arrow button if the chlorine level is too high.</li> <li>3. Sodium bromide may have been introduced into the pool by using a bromine-based algaecide. The DPD (red color) chlorine test reagent will give false readings if bromine is in the water. The OTO (yellow color) test kit must be used which can test for bromine and chlorine.</li> </ol>
Purifier display	Purifier locked at 1%	If the water temperature is 55°F (10°C) or colder the Pool Pilot has automatically turned the Chlorine output down to 1% to avoid over-chlorination. Bacteria and algae stop growing at this temperature, so this should not be a problem.
	Purifier % fluctuates from adjusted value	The AutoPilot unit has a patented process for automatically increasing and reducing the chlorine output as the temperature of the water fluctuates. It is normal for the % output to increase as the water temperature increases, and to decrease as the water temperature decreases.
Blank display	The Pool Pilot Display is blank.	<ol style="list-style-type: none"> <li>1. If the display is in bright sunlight, then shade the display to read.</li> <li>2. Verify external time clock has not turned off power to Control Unit. (Temporarily override the time clock, if desired, to check the Nano.)</li> <li>3. Verify local shut off switch and/or main circuit breaker for Control Unit is turned on.</li> <li>4. If power is provided to unit by an external control device, verify power is provided to and from the device.</li> <li>5. Fuse may be blown. See fuse replacement in maintenance section.</li> </ol>
Cooling	Unit is not generating Chlorine	<p>Internal temperature of unit has exceeded "Shutoff Temp", viewable on Setup Menu. Will turn off chlorine generation for five (5) minutes or until temperature decreases.</p> <ol style="list-style-type: none"> <li>1. Wait until unit cools down.</li> <li>2. Move control unit to a shaded area if too hot.</li> </ol>

# APPENDIX

## Declaration of Conformity

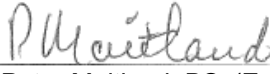
<b>Declaration of Conformity</b> (according to ISO/IEC Guide 22 and EN 45014)	
<b>Manufacturer's Name:</b>	Aquacal Autopilot Inc.
<b>Manufacturer's Address:</b>	2737 24 <sup>th</sup> Street North, St. Petersburg, Florida USA 33713.
<i>declares that the product:</i>	
<b>Product Name:</b>	Pool Pilot Nano
<b>Model Number:</b>	75041.
to which this declaration relates, <b>meets the essential health and safety requirements</b> and is in conformity with the relevant EU directives listed below:	
<b>EU EMC Directive 89/392/EEC</b> <b>EU Low Voltage Directive 73/23/EEC</b>	
using the relevant sections of the following EU standards and other normative documents:	
EMC:	EN55014-1:2000 + A1 + A2:2002 EN55014-2:1997 + A1:2001 EN61000-3-2:2006 EN61000-3-3:1995 + A2:2005
Safety:	EN 60335-1-2002 + A11.2004 + A1.2004 IEC 60335-1.2002 + A1.2004
Fort Lauderdale, Florida USA. March 10th 2010. (Place and date of issue)	 Peter Maitland, BSc(Eng), CEng.

## FCC Compliance:

NOTE: This equipment has been tested and found to comply with the limits for a Class B digital device, pursuant to part 15 of the FCC Rules. These limits are designed to provide reasonable protection against harmful interference in a residential installation. This equipment generates, uses and can radiate radio frequency energy and, if not installed and used in accordance with the instructions, may cause harmful interference to radio communications. However, there is no guarantee that interference will not occur in a particular installation. If this equipment does cause harmful interference to radio or television reception, which can be determined by turning the equipment off and on, the user is encouraged to try to correct the interference by one or more of the following measures:

- Reorient or relocate the receiving antenna.
- Increase the separation between the equipment and receiver.
- Connect the equipment into an outlet on a circuit different from that to which the receiver is connected.
- Consult the dealer or an experienced radio TV technician for help.



2737 24th St. North  
St. Petersburg, FL 33713  
1-727-823-5642